

Power Systems Design

EUROPE

Empowering European Innovation

March 2007

Energy Efficient Fluorescent Designs

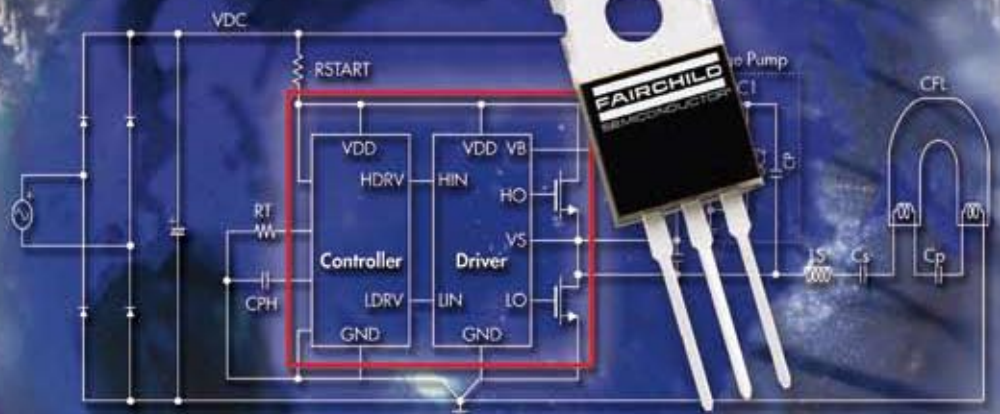

PowerLine ▶
PowerPlayer
MarketWatch
TechTalk
Design Tips
Lighting Systems

Energy-saving inverter designs: 50% less cost, size and time.

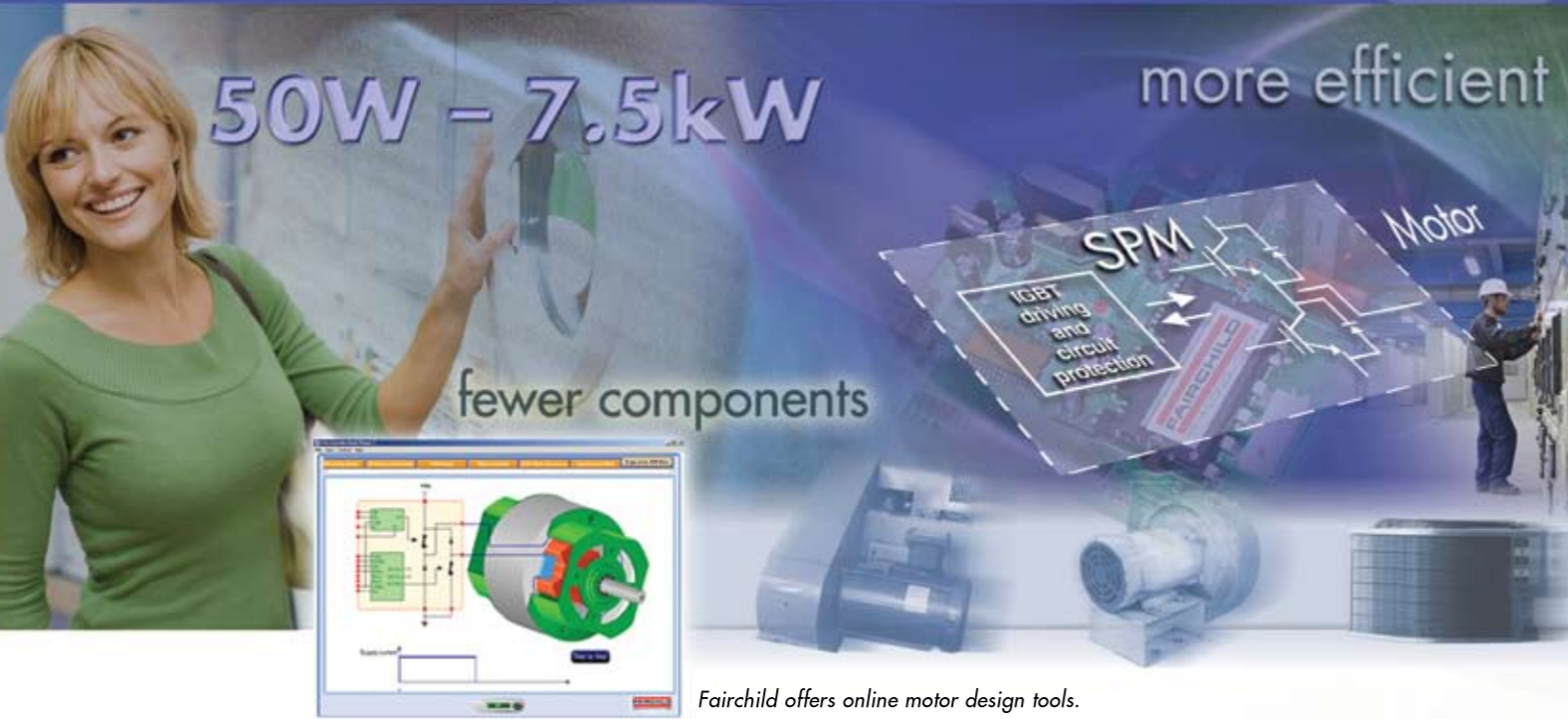

Fairchild offers online motor design tools.

Integrated power modules simplify your designs

Smart Power Modules (SPM™) are just what you need to dramatically improve the performance/cost ratio of variable speed designs. Available for motor ratings from 50W to 7.5kW, every SPM includes:

- An integrated drive and protection solution built with our leading power components
- Fairchild's combined power and motion design expertise
- Best-in-class packaging technology that reduces board space while providing excellent thermal performance

Our SPM series includes solutions for consumer and industrial inverter designs, as well as options for switched reluctance and PFC.

If you prefer to build your own drive with discrete components, all the building blocks inside our SPM, including IGBTs, HVICs and MOSFETs are also available for your motion power path.

If energy and cost savings are your problem, Fairchild has your solution.

For more motor design information, including online design tools and application notes, visit www.fairchildsemi.com/motor

SPM Series	Motor Ratings	Description
Motion-SPM	50W to 7.5kW	3-phase IGBT or MOSFET inverter
SRM-SPM	2kW	Single-phase asymmetric bridge
PFC-SPM	1kW to 3kW	Partial switching converter module
	3kW to 6kW	Power Factor Correction (PFC) module

problem **solved**

www.fairchildsemi.com

the **power**
franchise™

Power Systems Design

Viewpoint

Welcome to the future... 2

Industry News

Maxwell Technologies Receives Largest-Ever 3 Million-Unit "D Cell" Ultracapacitor Order 4

Microsemi Opens Taiwan Design Center 4

Rutronik and Infineon Extend their Distribution Agreement 4

TTI Achieves More than Double Industry Growth 4

UR Group Appoints New Area Sales Manager for Northern England 6

PSMA Releases 2006 Technology Roadmap Workshop Report 6

Anderson Power Products® Announces Enhanced Web Site 6

PowerLine

Fast Transient Response DC/DC Power Module for 3-GHz DSP & High Performance POL Systems 8

PowerPlayer

The Challenge of Powering Deep Sub-Micron CMOS Loads, By Paul Greenland, Enpirion 10

MarketWatch

Rise of Portable Devices a Powerful Concern, By Marijana Vukicevic, iSuppli Corporation 12

Design Tips

High Frequency Power Transformer Measurement and Modeling, By Dr. Ray Ridley, Ridley Engineering 14

TechTalk

Have Bricks Hit the Wall? Reported by Cliff Keys, Editor-in-Chief, PSDE 20

Cover Story

The "Simple" Legacy Continues and Flourishes, By Frederik Dostal, National Semiconductor 24

Portable Power

Moving to Smaller Solutions, By Thomas Schaeffner, Texas Instruments 28

Power Supplies

Designing for Point of Load Without Mystery, By Mikhail Guz, Power-One Inc. 31

Industrial Communications

Trends in Industrial Communications, By Alexander Jaus, Avago Technologies 33

Trench MOS Technology

Trench MOS Barrier Schottky Rectifiers Address Weaknesses of Traditional Planar Schottky Devices, By Max Chen, Henry Kuo & Sweetman Kim, Vishay Semiconductors 35

Power Supplies

Design Considerations for Compact and Highly Flexible Power Supplies, By Gary Bocock, XP Power 40

Lighting Systems

Higher Efficiency Drives Incandescent Lamp Replacement, By Vajapeyam Sukumar, Fairchild Semiconductor 43

Power MOSFETs

Threshold Voltage Thermal Coefficient (TVTC) in Power MOSFETs, By Giuseppe Consentino, STMicroelectronics 46

New Products

..... 49

Power Systems Design Europe Steering Committee Members



Member	Representing	Member	Representing
Eric Carroll	ABB Switzerland	Tony Armstrong	Linear Technology
Arnold Alderman	Anagenesis	Hans D. Huber	LEM
Heinz Rüedi	CT-Concept Technology	Ralf J. Muenster	Micrel
Claus Petersen	Danfoss	Michele Sclocchi	National Semiconductor
Paul Greenland	Enpirion	Kirk Schwiebert	Ohmite
Marion Limmer	Fairchild Semiconductor	Christophe Basso	On Semiconductor
Dr. Reinhold Bayerer	Infineon Technologies	Balu Balakrishnan	Power Integrations
Dr. Leo Lorenz	Infineon Technologies	Chris Ambarian	Qspeed Semiconductor
Davin Lee	Intersil	Uwe Mengelkamp	Texas Instruments
Eric Lidow	International Rectifier	Peter Sontheimer	Tyco Electronics

POWER Systems Design

AGS Media Group
146 Charles Street
Annapolis, Maryland 21401 USA
Tel: +410-295-0177
Fax: +510-217-3608
www.powersystemsdesign.com

Editor-in-Chief
Cliff Keys
cliff.keys@powersystemsdesign.com

Contributing Editors
Liu Hong
Editor-in-Chief, Power Systems Design China
powersdc@126.com

Marijana Vukicevic, isuppli Corporation
mvukicevic@isuppli.com

Dr. Ray Ridley, Ridley Engineering
ridleypower@aol.com

Publishing Director
Jim Graham
jim.graham@powersystemsdesign.com

Publisher
Julia Stocks
julia.stocks@powersystemsdesign.com

Circulation Management
Kathryn Ferris
kathryn@powersystemsdesign.com

Research Director
Meghan Corneal
meghan.corneal@powersystemsdesign.com

Magazine Design
Beata Rasmus, Eyemotive
beata@eyemotive.com

Production Manager
Melody Zhang
melody@action-new.net

Registration of copyright: January 2004
ISSN number: 1613-6365

AGS Media Group and Power Systems Design Europe magazine assume and hereby disclaim any liability to any person for any loss or damage by errors or omissions in the material contained herein regardless of whether such errors result from negligence, accident or any other cause whatsoever.

Send address changes to:
circulation@powersystemsdesign.com

Volume 4, Issue 2



Lighting Leads the Way



When we discussed the editorial calendar for 2007, we thought it important to cover the most recent trends in Lighting. Not just what is happening with the new LED offerings, but also with compact fluorescent technology and other forms, to report what is out there in the market, right now.

We have seen leaps forward in lighting, especially in LED technology, both in the devices themselves and the circuits for driving and controlling them. You will see a fair collection in the forthcoming news pages and the response has been so overwhelming, that we will continue with part two in the theme of lighting in the May issue.

Of course, we have all seen the various arguments and in some cases legislation for the energy savings that these products can bring. But it doesn't happen overnight and there's a huge installed base to consider. Our contributed articles in this issue and again in May, will undoubtedly give you much food for thought.

At the various trade fairs I report, I am quite literally, dazzled by the intensity of light achieved by LEDs and wondered how the heat generated could be extracted. But as these devices are not only bright but also efficient in comparison to their incandescent counterparts, we can expect an accelerated uptake in the many forms now appearing on the market as well as those still on the drawing boards.

Recently, I visited, or rather raced around, the APEC conference which took place in Anaheim, Southern California. There was a wealth of power products and technology to be seen, played with and experienced. Adjacent to the parallel-running conference program, was a very respectable exhibition, naturally focused only on power products.

The thing I liked about the conference, was that I could meet several power companies in one location...an intensive, but valuable update which I shall report more fully in the next issue.

Statistics for the conference are better than ever this year with attendance up by 20%. A record 3,000 delegates and visitors enjoyed the presentations, displays and demos from 166 exhibitors.

Next year will be even better with a forecast 200 plus exhibitor participation. It's already filling up fast according to the organizer. The venue for this event will be the convention centre, Austin, Texas. I can really recommend making the trip.

On my short visit to Silicon Valley companies after APEC, I noticed a distinct upsurge in progress for the 'power push'. There are real strides forward appearing and I am excited to be at the front end in reporting these latest developments.

Coming up in the next couple of months we have a feast of power activity. My counterpart for Power Systems Design China will be reporting on PCIM in Shanghai, where the magazine is official sponsor. I shall participate at PCIM here in Nuernberg, Germany which takes place at the end of May. Here, I shall be running a Forum on the topic of lighting where leading figures from the industry will present and participate in a lively floor discussion. Naturally I shall report for the benefit of those who cannot attend.

In the next issue, we will be introducing another new, regular feature we call the 'Green Page'. Here we'll discuss issues and policies on power efficiency, environmental and regulatory issues. I will be very receptive to any inputs on this and will keep the topic wide open to capture an appealing cross section for you.

So, on to the current issue. I hope you enjoy the content and please keep the valuable feedback coming.

Cliff Keys

Editor-in-Chief, PSDE
Cliff.Keys@powersystemsdesign.com



To help your innovation we make ourselves small.

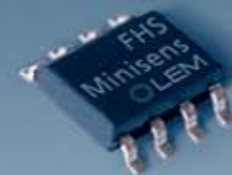

Minisens, FHS Current transducer

Minisens is taking miniaturization to the next level as it is a fully fledged current transducer for isolated current measurement including magnetic concentrators in an IC SO8 size. This allows you to include all the functionalities you are looking for into the space that you have available.

- Non-contact current measurement with no insertion loss
- Isolation provider
- Attractive price
- Flexible design allows a wide range of current measurement from 2-70 A_{RMS}
- +5V power supply
- Access to voltage reference
- Ratiometric or fixed gain and offset
- Standby mode pin
- Dedicated additional fast output for short circuit detection
- High performance gain and offset thermal drifts

www.lem.com

At the heart of power electronics.



Cree XLamp® XR-E LEDs Chosen For Favour Light Camp Lanterns



Cree has announced that Favour Light Enterprise Limited, one of the world's largest flashlight makers, has selected Cree's new XLamp® XR-E power LEDs for its innovative LED camping lanterns and a number of new flashlight models.

Cree XLamp XR-E LEDs lead the industry in brightness and efficiency, critical features in battery-powered, portable lighting applications such as hand-held flashlights. XR-E LEDs also produce the high-quality, uniform white light required by flashlight manufacturers. The new white Cree XR-E LEDs produce typical luminous flux of 80 lumens at 350 mA, yielding 70 lumens per watt, and establish a new class of LED performance.

"Cree power LEDs bring a whole new level of quality light to our practical, general-purpose personal lighting devices," said Shiu Shing, Favour Light managing director. "We can now provide our customers with extremely bright, LED-based products at reasonable

prices."

"Favour Light is a strong player and rapid innovator in the portable lighting market," said Norbert Hiller, Cree general manager and vice president for XLamp power LEDs. "It's exciting to see a high-volume, value-priced flashlight manufacturer like Favour Light choose the brightest LEDs. Their camping lanterns and general-purpose flashlights are available at varying price points, which brings the long-life and high brightness of quality Cree LED lights to a much larger customer base."

www.cree.com/xlamp

www.favourlight.com

Maxwell Wins Order for 100,000m² of Ultracapacitor Electrode Material from Licensee in China

Maxwell Technologies has announced that it has received a purchase order for 100,000 square meters of its proprietary ultracapacitor electrode material from Shanghai Sanjiu Electric Equipment Company, Ltd., (Sanjiu) which is preparing to introduce a line of ultracapacitor products based on Maxwell's cell architecture and high-performance electrode

for the Chinese transportation, electric utility and industrial markets, with a specific focus on Shanghai.

The order is to be filled over the balance of 2007, based on Sanjiu's planned production of 100,000 large cell 3,000 farad ultracapacitors cells for the year. It was placed under the terms of an April 2006 ultracapacitor

technology license and exclusive electrode material supply agreement between Maxwell and Sanjiu's joint venture parent companies, Shanghai Urban Electric Power Investment Development Corporation (SUEP) and the Ruihua Group.

www.maxwell.com

Nextreme Thermal Solutions Names New Chief Technology Officer



tech and defense/aerospace industries, has

Nextreme Thermal Solutions, manufacturer of advanced thin film thermoelectric components designed and produced to address the thermal management needs of the electronics, photonics, bio-

recently appointed Dr. Seri Lee as Chief Technology Officer.

Prior to joining Nextreme, Dr. Lee served as Senior Thermal Scientist for the Silicon and Platform Solutions Group at Intel Corporation, where he was responsible for executing corporate thermal directions for consumer products and technology development requirements. As an active member of the ASME Heat Transfer Division K-16 Committee on Heat Transfer in Electronic Equipment and the IEEE/SemiTherm Executive Committee, Dr. Lee brings a wide range of thermal management experience to Nextreme.

"I am excited to welcome Dr. Lee to Nextreme, as his experience is a part of our plan to build a world-class technology team focusing on electronic and opto-electronic packaging and thermal management," said Jesko von Windheim, CEO at Nextreme. "I believe that Dr. Lee's addition positions the company to address many of the most demanding issues in thermal management for advanced technology products; in addition, Dr. Lee will bring a new focus to the company's efforts in the area of thermoelectric power generation."

www.nextremethermal.com

Ford Selects OSRAM for LED Interior Lighting



OSRAM Opto Semiconductors will provide LED technology that will give a number of future Ford products the same harmonious, Ice Blue interior lighting in instrumentation, radios, climate control and switches.

Ice Blue is Ford's newest interior that will be incorporated into many new vehicles.

Over the past decade, OSRAM Opto Semiconductors Inc. has collaborated with Ford to bring distinctive interior lighting into many products and in the last five years, LED technology has become a sought after light source among automobile manufacturers due to styling flexibility, energy efficiency, unlimited colour options and high reliability.

www.osram-os.com

Tiny, 1W, 3kV Isolated DC/DC Converters

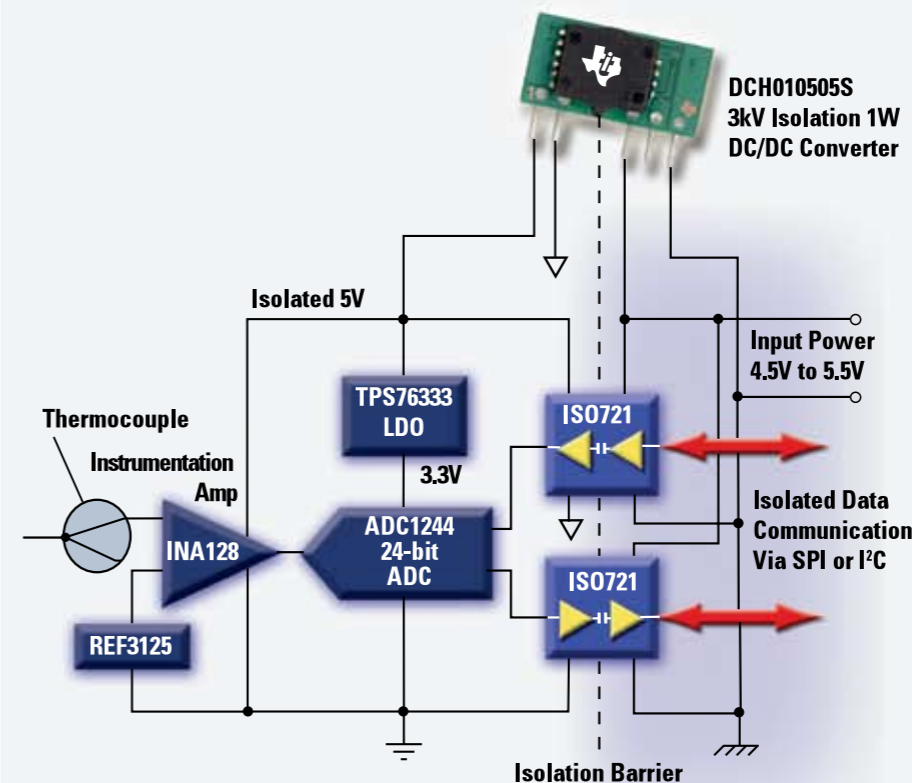

► Applications

- Data acquisition
- Industrial control and instrumentation
- Test and measurement
- Medical instrumentation
- Professional audio
- Ground loop elimination

► Features

- 3kV isolation
- Low ripple
- Up to 78% efficient
- Industry standard SIP-7 package/footprint
- Single or dual output
- UL60950 certified product
- 54 million hour MTBF

The new **DCH01** DC/DC converters from Texas Instruments provide up to 1W of isolated power with 3kV isolation in an easy-to-use industry-standard SIP package. Available with single or complementary dual outputs, the DCH01 products are ideal in a variety of applications.

New DCH01 DC/DC Converters from Texas Instruments

Device	Input Voltage	Output Voltage	Output Current (mA)
DCH010505S	4.5 to 5.5	5	200
DCH010505D	4.5 to 5.5	±5	100
DCH010512S	4.5 to 5.5	12	83
DCH010512D	4.5 to 5.5	±12	42
DCH010515S	4.5 to 5.5	15	67
DCH010515D	4.5 to 5.5	±15	33

Order samples and download datasheets now!



www.ti.com/dch01-e ☎ +44 (0) 1604 66 33 99

Technology for Innovators™

TEXAS INSTRUMENTS

Adoption of Power Integrations' EcoSmart® Technology Accelerates as Energy Savings Surpass \$2 Billion



Power Integrations has announced that its power conversion ICs with EcoSmart technology have saved consumers and businesses

worldwide an estimated \$2 billion on their electricity bills. The company's ICs are used to replace outdated, energy-wasting power supplies such as copper-and-iron linear transformers, also known as "energy vampires." The company calculates that for every linear transformer that is replaced by EcoSmart ICs the consumer saves between \$3 and \$6 on their energy bills over the average product life. Power supplies are a necessity for almost every electronic product. However, power supplies based on old technologies such as linear transformers have efficiency levels as low as 30 percent and rarely exceeding 50 percent, so they consume far more power than is actually required to operate the equip-

ment that they supply. Moreover, these older power supplies also consume a significant amount of power when their products are in "sleep" or standby modes. In contrast, Power Integrations' EcoSmart ICs enable power supplies that operate at substantially higher efficiency levels and reduce standby power waste by up to 95 percent without adding to the cost of the end product.

EcoSmart products cover the power range of more than 70 percent of all AC-to-DC power supplies built worldwide: LinkSwitch®, 0 to 5 W; TinySwitch®-III, 5 to 28W; and TOPSwitch®-GX, 7 to 210 W.

www.powerint.com

Nokia Growth Partners Leads Growth Financing Investment In Summit Microelectronics

Summit Microelectronics has announced Nokia Growth Partners, the later-stage focused investment arm of Nokia, has led a growth financing investment round in the company.

The \$10M round includes Nokia Growth Partners contributing \$4M, with existing investors Norwest Venture Partners, August Capital, Pequot Ventures, Bessemer Venture Partners, Hotung Capital Management and others contributing \$6M.

"Mobile phones no longer just make voice calls, but connect to the Internet and act as our mobile camera, music player, navigation device, and even our mobile television. This

growing functionality raises the importance of power management. Nokia Growth Partners is pleased to lead this investment round. Summit has assembled a world-class team specializing on these issues and has built unique products to help meet the rising power performance demands of mobile device manufacturers," said Rob Trice, of Nokia Growth Partners.

"Having the world's largest user of power management ICs help fund our growth is very exciting," added Pat Brockett, Summit's President and CEO. "It reinforces our belief that Summit's technology will become pervasive in consumer and battery powered applications.

The challenges of increasing complexity and battery run-time, coupled with tighter time-to-market pressure, have rendered the traditional 'hard-wired' analog building-block approach obsolete."

"Summit's programmable power management technology is ideal for portable and handheld systems with applications ranging from intelligent battery management to powering next generation organic LED (OLED) displays," continued Brockett.

www.summitmicro.com

Texas Instruments Focuses on Power Supply Design Innovation with European 2007 Seminar Series



After more than 25 years experience in educating power supply designers with innovative design concepts, Texas Instruments has announced the European schedule for its 2007 Power Supply Design Seminar Series.

TI's leading power management gurus will conduct a series of one-day seminars in 22 cities in Europe beginning April 16.

The 2007 series, the 18th since introduced by Unitrode in 1977, provides rich technical and practical presentations that combine new advanced power supply concepts, basic design principles and 'real-world' application

www.ti.com/europe/power07

Power Events

- **APEC 2007**, Feb 25 - March 1, Anaheim, California, USA, www.apec-conf.org
- **PCIM China 2007**, March 21-23, Shanghai, China www.pcimchina.com
- **electronicaChina 2007**, March 21-23, Shanghai, China <http://www.global-electronics.net/?id=21317>
- **PCIM Europe 2007**, May 22-24, http://en.wikipedia.org/wiki/N%C3%BCrnberg_%28disambiguation%29 Nürnberg, Germany <http://www.mesago.de/en/PCIM/main.htm>
- **The China International Power Supply Show (CPS EXPO)**, June 13-15, Shenzhen, China <http://expo.dianyuan.com/>

More µModule Power Supplies

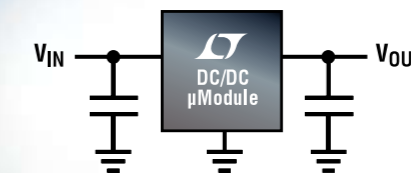
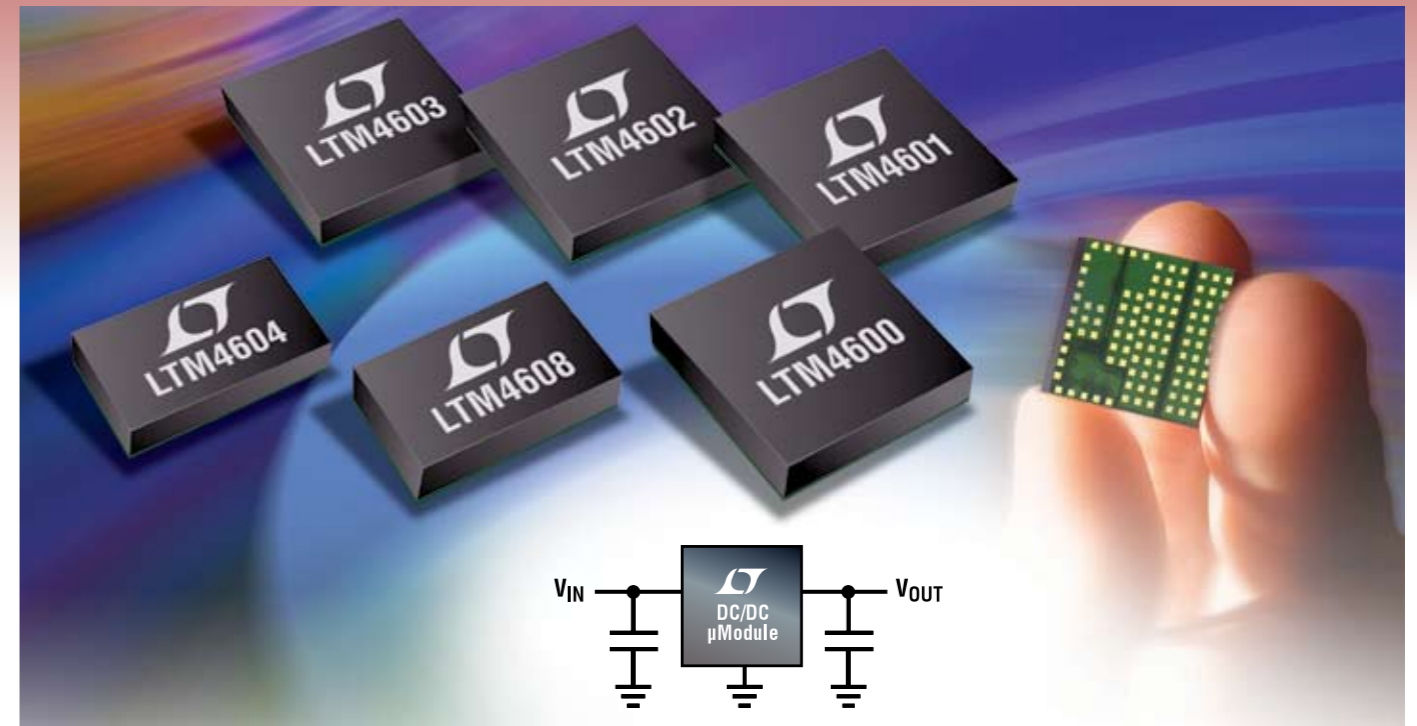

High Reliability DC/DC µModule Family: 2.5V-28V Input, Up to 12A Out (PolyPhase for >12A)

Our growing family of µModule™ DC/DC converters simplifies high density power supply design and minimizes external components. This family features compact and low profile packages, proven reliability, wide input voltage ranges and high output currents with PolyPhase® operation for true scalability. We have also added tracking, margining, frequency synchronization and differential remote sense capability.

▼ New DC/DC µModule Family

VIN: 4.5V-28V; VOUT: 0.6V-5V				LGA Package			
Part No.	I _{OUT} (DC)	Current Share	PLL	Track, Margin	Remote Differential Sense	Height	Area
LTM [®] 4602	6A	Combine two for 12A to 24A or 4x LTM4601 for ≤48A				2.8mm	15x15mm
LTM4603	6A		✓	✓	✓		
LTM4603-1	6A		✓	✓			
LTM4600	10A						
LTM4601	12A		✓	✓	✓		
VIN: 2.5V-5.5V; VOUT: 0.8V-3.3V							
LTM4604	4A	4x for 16A-32A	✓	✓		2.3mm	15x9mm
LTM4608*	8A		✓	✓	✓	2.8mm	15x9mm

*Future Product

▼ Info & Online Store

www.linear.com/micromodule

Tel: 1-408-432-1900



LTC, LT, LTM and PolyPhase are registered trademarks and µModule and ThinSOT are trademarks of Linear Technology Corporation. All other trademarks are the property of their respective owners.



Facade Illuminated in Fascinating Display of Colours

The new facade of the Regensburg shopping centre, KÖWE, captivates shoppers with a myriad of harmonised colour changes. This unusual optical impression is achieved by 2,448 Golden Dragon LEDs from OSRAM Opto Semiconductors, which backlight the glass facade.

The KÖWE shopping centre in Regensburg, Germany was recently modernised after 15 years of its existence. In the course of these renovations, the entrance front was given a glass facade with an advertising banner integrated in the upper third. The top and bottom sides of the banner were provided with 816 RGB modules equipped with a total of 2,448 high-power LEDs from OSRAM in the colours red, green and blue. Their light is directed to shine up and down, parallel to the wall. A special secondary lens on the thin film LEDs and an intelligent colour control system ensure a homogeneous and dynamic colour progression. This allows individual patterns with over 16 million colours to be displayed on the entrance front of the KÖWE – from unicoloured areas to colourful stripes and elegant colour progressions.



Caption: Golden Dragon LED showcase shopping centre.

“The long life of these LEDs and the resulting low maintenance costs were crucial factors in the decision to use light-emitting diodes in this project,” explains Marco Friedrich, Manager of LI-EX, the company responsible for the lighting design and technical implementation of the facade. “The coloured LEDs used have a life of up to 100,000 hours. As a further advantage, these point light sources are the brightest single-chip LEDs from OSRAM. Furthermore, they are small and use little energy. In colour-change mode, the 2,448 LEDs at the KÖWE facade consume a mere 1,800W, a great power saving in these energy efficient times. In addition, we were able to use these LEDs to produce a dynamic colour progression across the entire

facade,” adds Mr. Friedrich, a certified partner in OSRAM’s LED Light for you network – a platform at www.ledlightforyou.com providing competent information on the subject of LED lighting.

The Golden Dragon LED family is OSRAM Opto Semiconductors’ high performance LED requiring special considerations in thermal management and electrical implementation.

With a higher current there is higher power, and therefore more heat to dissipate. The Golden Dragon LED package is optimized for removing this heat efficiently. With an integrated heat slug (also known as a heatspreader) the thermal performance is far superior to

standard LEDs.

Golden Dragon LEDs are delivered on tape and reel and have a flat top to allow pick-and place machinery installation. All contacts (including the heat slug) are soldered in place using standard infrared reflow processes (Surface-mount component processing). Up to now the Golden Dragon is the only high power LED in the market

which is capable to be processed according to these cost effective standard assembly techniques.

www.osram-os.com

www.ledlightforyou.com

HIGH-PERFORMANCE ELECTROMECHANICAL SYSTEMS DESIGN SOFTWARE

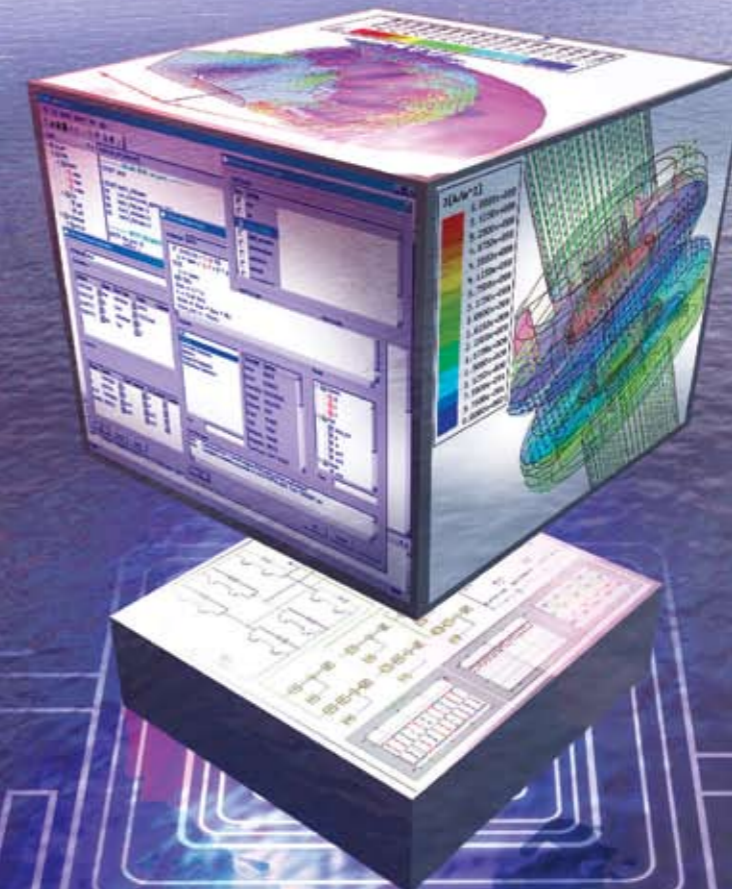

MAXWELL®
3D electromagnetic-field simulation and parameter extraction for component design and optimization

SIMPLORER®
System/circuit simulation and statistical analysis for multi-domain, mixed-technology design

ePHYSICS™
Thermal and stress analysis for electromechanical components

OPTIMETRICS™
Parametric, optimization, sensitivity analysis



UK / EUROPEAN HEADQUARTERS
TEL: +44 (0) 1256 347788
EMAIL: uksales@ansoft.com

COPENHAGEN, DENMARK
TEL: +45 32 88 22 90
EMAIL: nordic@ansoft.com

MUNICH, GERMANY
TEL: +49 89 68 086 240
EMAIL: info_de@ansoft.com

PARIS, FRANCE
TEL: +33 01 39 56 67 99
EMAIL: info@ansoft.com

ROME, ITALY
TEL: +39 06 591 6845
EMAIL: italy@ansoft.com

Enabling Technologies for Energy Efficiency

Dr. Leo Lorenz, Infineon Technologies China Co., Ltd, Shanghai, China

Power semiconductor devices and smart power IC's represent the driving force behind developments in the field of power electronic system engineering, primarily used to control the flow of electrical energy between the energy source and the load with great precision, providing extremely fast control times and lowest dissipated power.

The pressure is really on in these times to use energy resources efficiently. The miniaturization of systems and introduction of intelligent power management units will certainly continue to be the prime mover for the future. Legislative bodies and governments are now helping in this and even the traditional incandescent light bulb looks now in line for replacement by the more efficient, power managed products.

Advances in power electronic systems over the last three decades have been marked by 5 major inventions: light triggered thyristor (LTT's) in the top end power range, IGBT's in the high and mid range power end, power MOSFET's in the low-end power range, SiC devices for ultra low loss applications and SMART power IC's for monolithic system integration.

Infineon Technologies has worked to be clear market leader in these 5 segments, becoming the benchmark company for industrial and automotive system solutions. Close cooperation between silicon experts, system engineering and the company's advanced packaging development team set many benchmarks for discrete devices such as 3D multi technology embedded power solutions and temperature ratings up to 175C.

Following the power electronics system roadmap towards energy efficiency,



high power density design, system reliability & cost reduction, Infineon's power devices development is based on four main principles:

- Bipolar devices for LTT
- Precisely controlled carrier modulation for IGBT's
- Carrier compensation for Super Junction (CoolMOS) transistors
- SiC based devices for HV-Schottky Diodes

The reduction in device losses, improvement of electrical and thermal performance along with world-class ruggedness and reliability are the guidelines for future developments.

As an example, integration of a light sensitive region to an amplifying gate structure into a thyristor cell has simplified the trigger circuitry and enabled production of 6000A/8kV devices while extremely high system reliability has been achieved by monolithic integration of over-voltage, dv/dt and forward recovery protection.

The latest cell design and vertical

Si optimization resulted in the Trench-Fieldstop IGBT (Trench-FS-IGBT). This concept is now applied throughout the whole device family (600V-6.5kV;1A-4000A).

Low Voltage Power MOSFET development is driven by ultra high cell density designs and new chip contacting technologies to eliminate parasitic inductance, minimize package related electrical resistors and optimize thermal management. The advanced trench transistor concept provides an extremely low R_{Dson} simultaneously with a low input capacitance, a new measure for fast switching LV-MOSFET in all DC/DC applications for CPU core supply.

The merged SiC-Schottky diode with SiC-pn diode set a new benchmark in all electrical /thermal features and provides stable avalanche operation for a unipolar diode in SiC.

All these device concepts have huge further development potential. However, one common direction for the whole industry is in low loss components at high switching frequencies to achieve high efficiency, miniaturized systems at low cost. This is an extremely demanding goal requiring a dedicated resource investment.

The switching speed of all these power devices will inevitably go up. The real challenge for the industry driving future power converters will be to gain a deeper understanding of parasitic interference, chip interfacing technologies and thermal management. The multi disciplinary cooperation of experts from the chip industry, packaging development and electrical system engineering will become vital to this end.

www.infineon.com

Thermal Challenge: VRM

High Ambient / High Watt Dissipation / Low Air Flow

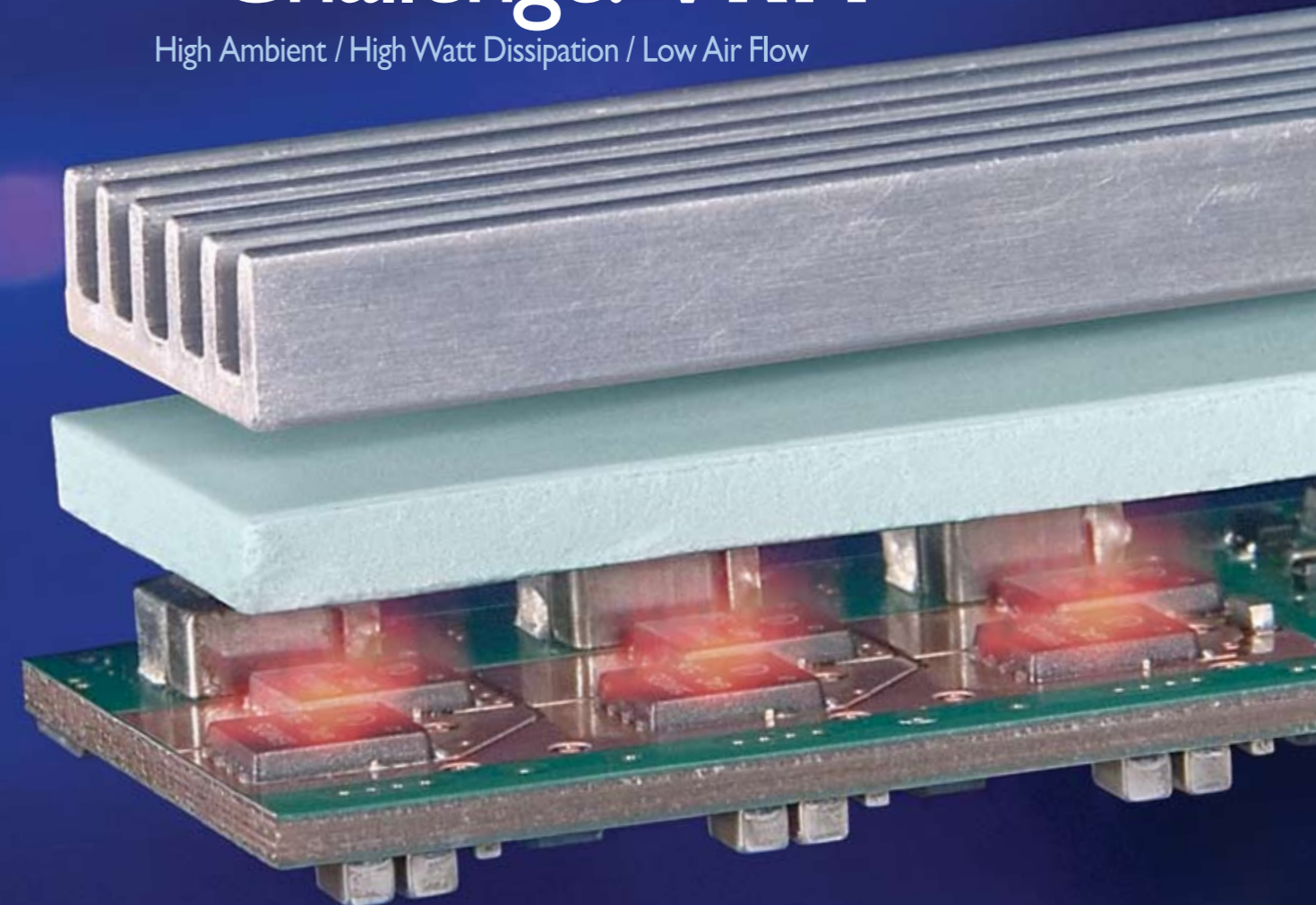

Solution: New Bergquist S-Class Gap Pad® 5000S35

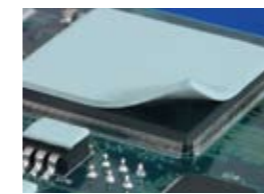

Gap Pad 5000S35's natural tack makes application clean and easy to handle.

Gap Pad 5000S35 is perfectly suited for high performance applications such as VRMs, BGAs and ASICs.

Bergquist's newest S-Class is the perfect combination of softness, low thermal resistance and high thermal conductivity. With a low bulk hardness (35 Shore 00) and high thermal conductivity (5.0 W/m-K) it conforms to demanding contours while maintaining its structural integrity. It is an ideal gap filling solution for applications with fragile components that can be damaged by harder materials that cause higher mounting pressure on components. Gap Pad 5000S35 is also an excellent solution for DVD drives, memory modules, and PC boards to chassis.



Excellent interfacing and wet-out makes GP5000S35 ideal for fragile components with demanding contours and stack-up tolerances.

Ultra soft S-Class integrity offers easy application.

Gap Pad 5000S35 has a natural tack that eliminates the need for additional adhesive layers that can inhibit thermal performance. Its super soft, yet elastic nature provides excellent interfacing and wet-out, even to surfaces with high roughness or topography. Gap Pad 5000S35 features an embedded-fiberglass reinforcement that makes it puncture, shear and tear resistant. No tearing, flaking or crumbling – just clean and easy handling during the assembly process.

FREE S-Class swatch kit.

Visit our web site or call to qualify for your FREE S-Class swatch kit with product details.



FREE Gap Pad S-Class Swatch Kit

Call +31 (0) 35 5380684 or visit www.bergquistcompany.com/coolrun



European Headquarters - The Netherlands. Tel: EU +31 (0) 35 5380684 • D +49-4101-803-230 • UK +44-1908-263663

Thermal Products • Membrane Switches • Touch Screens • Electronics • Labels and Graphic Overlays

Power Supply OEMs Light Up Our Lives

Electronic ballasts, LED illumination offer attractive growth opportunities

By Marijana Vukicevic, iSuppli Corporation

For years, the mainstream power-supply OEMs kept the market for consumer and industrial lighting on the sidelines. However, that all started to change about 15 years ago, when the power-supply industry became aware of the huge growth potential of the lighting market. With light ballasts already having transitioned from magnetic to electronic control, the next step in the global illumination market is underway: the move to replace conventional incandescent and fluorescent bulbs with Light-Emitting Diodes (LEDs).



industrial lights. To improve the energy efficiency of lights, manufacturers have offered fluorescent bulbs with electronic control circuitry, which replaced conventional magnetic ballasts. For the same amount of input power, a compact fluorescent lamp with electronic control delivers four times the brightness of an incandescent bulb. At the same time, the fluorescent lamp lasts six to eight times longer than the incandescent lamp.

A long day's journey into light

The evolution from magnetic to electronic control circuits in fluorescent bulbs was a long journey.

Magnetic-ballast designs that employ simple passive components are still in use, but the industry has realized the importance of electronic ballasts. However, not all electronic ballasts are controlled.

The basic electronic ballasts are self-oscillating and are based on simple discrete components that implement functions like start-up circuitry or even Power Factor Correction (PFC). These self-oscillating solutions account for about 50 percent of the electronic ballast market.

The other 50 percent of the electronic ballast market consists of solutions that integrate dimming features, along with PFC. Only a very small portion—less than 1 percent—of those ballasts are advanced, i.e. they use digital control and management.

Although the advantages of elec-

tronic-ballast fluorescent lighting are obvious, the market has not taken off as expected. The penetration of fluorescent lamps in homes and other venues is much higher in developed regions than it is in the third world. Thus, there is much room for growth in the market.

Enter the LED

Over the last decade, semiconductor Light Emitting Diodes (LEDs) have entered the global illumination industry.

A radical departure from incandescent and fluorescent lighting, solid-state LEDs have rapidly replaced traditional lighting sources in many existing applications while simultaneously creating new market niches. Today, LEDs are the lighting source of choice in diverse applications in the consumer, commercial and industrial sectors, including:

- Indoor and outdoor full-color displays
- Signage and traffic lighting
- High-intensity surgical lamps
- Automotive lighting
- Backlighting of small-sized LCDs in mobile phones
- Backlighting of large-sized LCDs in notebooks, TVs and desktop computers
- Mobile-phone keypad and camera flash lighting

Some of the obvious advantages of LED lighting are higher brightness and longer lifetime. For the same input power, LED lamps are five to six times brighter than fluorescent lamps. LED lamps last ten times longer than fluorescent lamps at the same power level.

The near monochromatic emission of LEDs and their resulting capability to tune their spectral characteristics will enable more dramatic growth of LED lighting applications. The number of LED lamp units is predicted to grow at 87 percent by 2011. By 2011, LED illumination sales will amount to one third of the fluorescent ballast market.

In order to succeed in the lighting market, LEDs lamps must undergo significant price reductions. Pric-

ing for the high-brightness LEDs used in lighting applications eroded by 26 percent in 2006. However, in order for LEDs to be widely accepted in lighting applications, this rate of price erosion must continue for several more years.

The highest commercialization rates for LED lighting are expected in the automotive industry, large-screen TVs and in general purpose lighting.

Figure 1 presents iSuppli's forecast of the commercialization timelines and growth rates for emerging LED lighting applications.

Marijana Vukicevic is the senior analyst, power management at the market research firm, iSuppli Corp., El Segundo, Calif. Contact her at mvukicevic@isuppli.com

For more information on the power-management market, read Vukicevic's latest report, entitled: *Turbulence on Horizon among Power MOSFET Suppliers*. To learn about this report, please visit: <http://www.isuppli.com/catalog/detail.asp?id=7832>

www.isuppli.com

Charge of the light brigade

Some of the largest consumers of

electricity are public commercial and

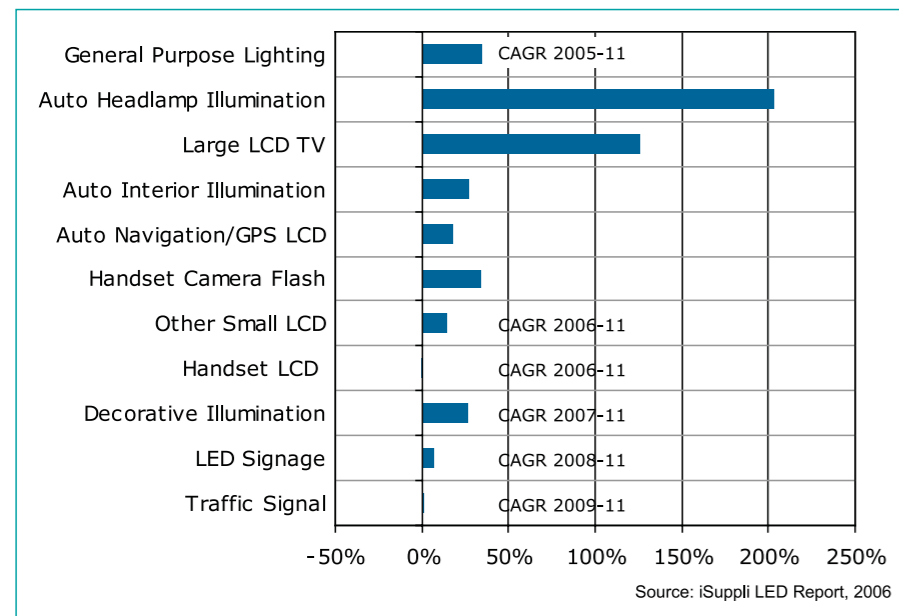

Figure 1. Commercialization Timelines and Growth Rates for Emerging LED Lighting Applications.

High Frequency Power Inductor Design

In this article, we continue the theme of custom versus off-the-shelf magnetics design. The relatively simple output inductor of a forward converter is used as an example to show the issues and pitfalls involved in trying to use off-the-shelf inductor designs for high-frequency power supply applications.

By Dr. Ray Ridley, Ridley Engineering

Power Inductor Design

When I first started my career in power electronics, over 25 years ago, all magnetic components were custom designed and manufactured. In our current power supply design workshops, we dedicate an entire day to the theory and practice of making custom inductors for switching power supplies. Attendees at the course design, analyze, and build their own inductors and transformers in the lab.^[1]

In the last few years, numerous companies have developed kits of standard parts aimed at the semiconductor companies to integrate into their designs. This proliferation of parts has recently led me to wonder if custom inductor design was becoming a skill belonging more to the past than the future.



Figure 2 shows two inductor designs, one developed in our workshop for a rugged 60-W converter, and the smaller low-cost, off-the-shelf part. You can see a significant size advantage of the standard component.

for overcurrent situations.

The off-the-shelf inductor, also 47 μH , had a single number assigned to it on the parts kit—a current rating of 5 A. Since the parts kit is aimed at the non-experienced power supply designer, it seems reasonable to assume that the inductor is suitable for a 5 A converter application

The parts are quite different in their design, as shown in Fig. 3. The custom-made inductor has a single-layer winding on an RM8 core, with a gapped center leg. The windings are a significant distance away from the center leg gap, essential to avoid proximity losses in the windings at high frequencies.

The off-the-shelf part is very different—a small drum-shaped core with many turns wound on the core in multiple layers. The air gap is large, and the windings are all situated in the middle of the gap. This violates all the rules



Figure 1: Building custom magnetics in our design workshop.

The 47 μH custom inductor was designed to operate continuously at 5 A, with plenty of margin

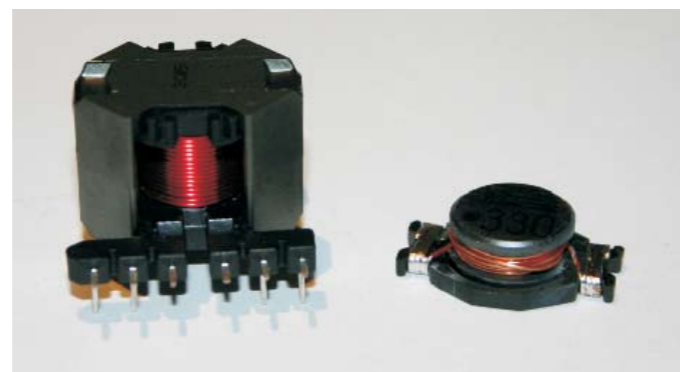
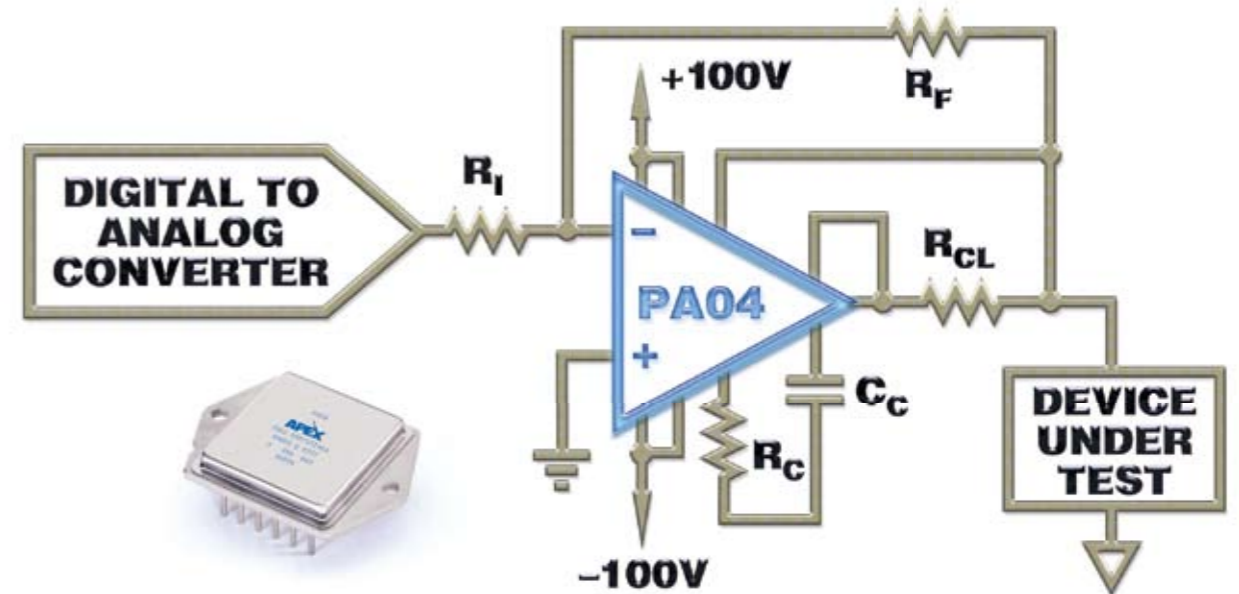

Figure 2: (a) 47 μH custom inductor and (b) off-the-shelf commodity component.

Power Solutions for Power Applications



With output current capabilities of up to 20A, the PA04 power op amp is the power solution for ATE pin driver programmable power supplies

Applications that demand power demand Apex. The Apex power series of power op amps features three models that bundle varying combinations of high performance voltage supply, thermal protection and reliability with output currents up to 30A. The PA04, PA03, PA05 also meet the demands of environmentally rugged operating conditions with their hermetically sealed metal packages. Simply put, these power op amps offer single package solutions for high power applications that are also cost effective.

Other High Power Applications

- Linear and rotary motor drives
- Sonar transducer drivers
- Yoke, magnetic field excitation
- High end audio

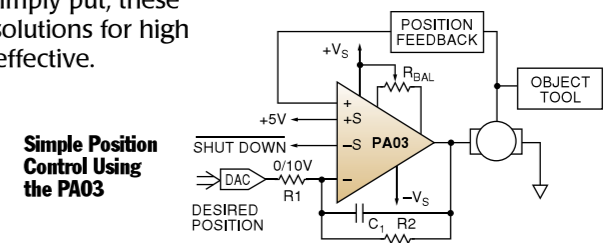

Model	Output Current	Supply Voltage	Power Dissipation	Slew Rate
PA04	20A	30V - 200V	200W	50V/ μs
PA03	30A	30V - 150V	500W	8V/ μs
PA05	30A	30V - 100V	250W	100V/ μs

Visit us online today at www.apexmicrotech.com/PSDE

- Data sheets
- Design tools
- Application notes
- Spice models
- Eval kits
- Request data book



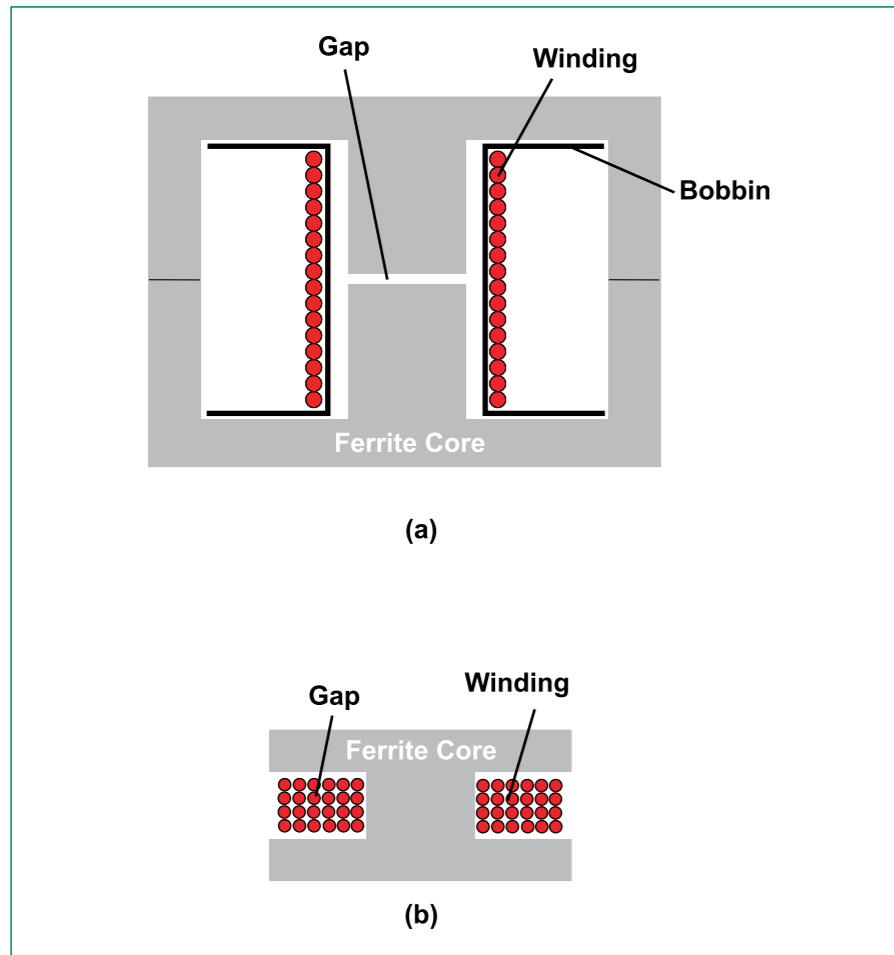

Figure 3: Cross-section of (a) RM8 core and (b) drum core showing winding layouts.

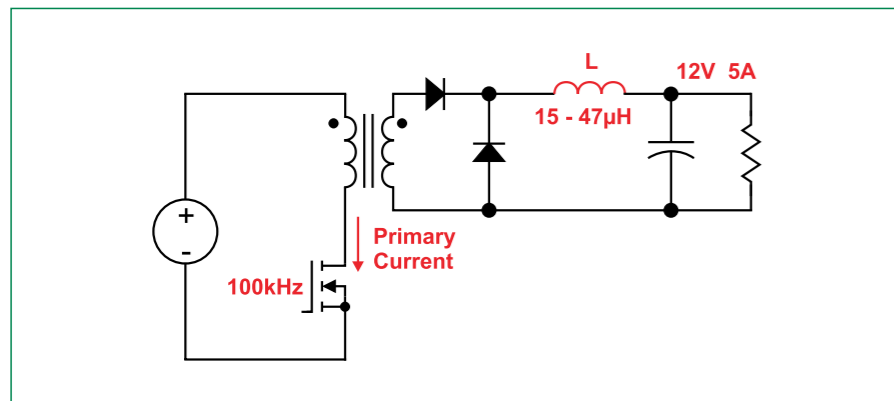

Figure 4: Forward converter schematic. Output is 12 V, 5 A, switching at 100 kHz. The reset circuit of the transformer is omitted for simplicity.

of high-frequency inductor design as I know them, but it's hard to argue with the size, cost, and current rating of the part compared to a custom design.

Forward Converter Testing

So how do these parts compare? Each was inserted into the forward converter shown in Fig. 4, and run at 4.5 A.

Initially, the waveforms for the two parts look the same, as shown in Fig. 5(a).

However, after 30 seconds of operation, the drum core design became very hot. The primary current started showing curvature, shown in 5(b), indicating the onset of saturation of the core material. The inductor temperature quickly

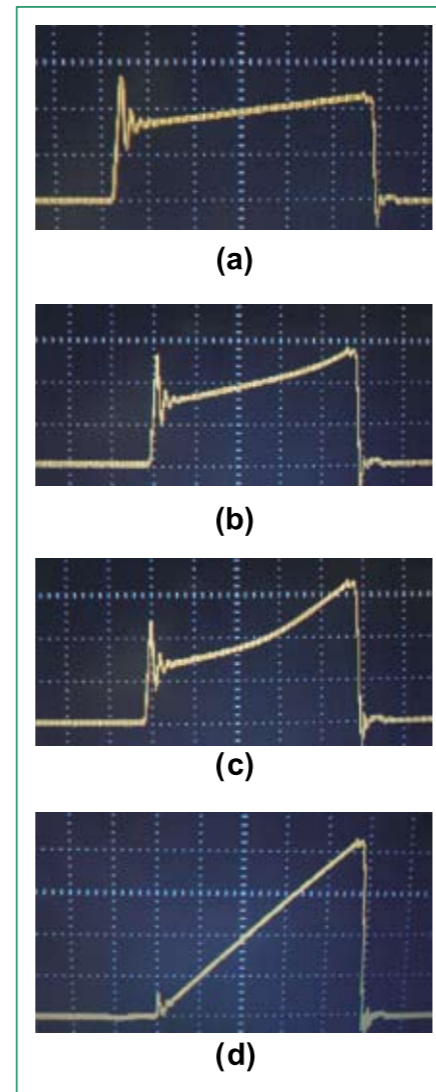

Figure 5: Primary switch current waveforms for a forward converter with a 47µH inductor: (a) proper operation with RM8 custom design, (b) drum core after 30 seconds at room temperature ambient, (c) drum core after 60 seconds, (d) drum core after 3 minutes operation.

rose further, shown in 5 (c). Testing was stopped after the waveform of Figure 5 (d) showed complete saturation, and smoke started coming out of the windings.

Clearly, the rating of 5 A, listed on the parts package, was not accurate. As a power engineer, knowing that a 5 A rating could have many meanings. I referred to the data sheet on the manufacturer's website, and found that this current referred to saturation current, not continuous current. The continuous dc current rating was only 2.8 A.

New LED Drivers Power 1W/3W LEDs up to 1A

LM3402/04 Regulators Offer Low Current-Sense Voltage to Reduce Power Loss and Deliver High Efficiency up to 95%

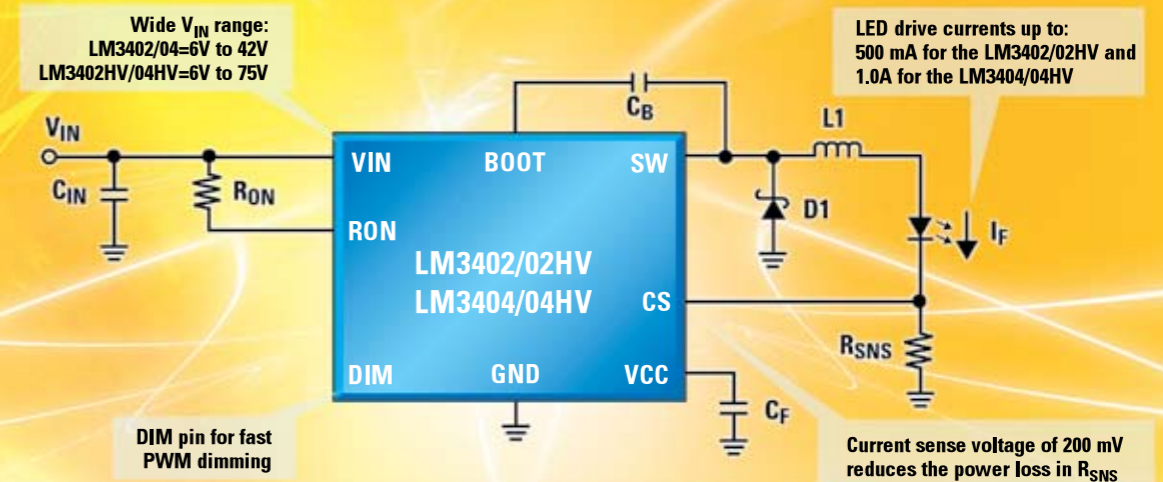

LM3402/04 Features

- Easy-to-use and low external parts count
- Switching frequency up to 1 MHz
- Constant on-time control with voltage feed-forward for nearly constant switching frequency over the full line voltage range
- Low 0.2V feedback reference minimizes power losses
- Low shutdown current when RON pin held low
- High voltage capability supports long strings of LEDs
- Choice of 0.5A or 1.0A peak current capability (LM3402/LM3404)

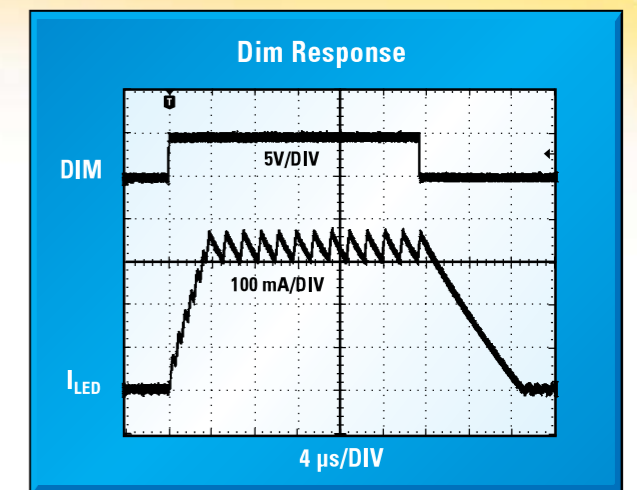

Ideal for use in automotive, industrial lighting, gaming/vending machines, general illumination, and architectural lighting applications



For samples, evaluation boards, datasheets and WEBENCH® online design tools, visit us today at:
led.national.com
 Phone: +44 (0) 870 240 21 71
 Email: europe.support@nsc.com

National Semiconductor
 The Sight & Sound of Information

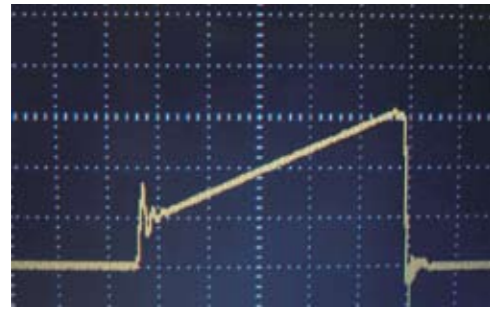

(a)

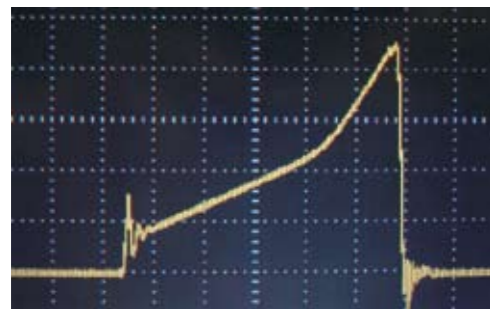

(b)

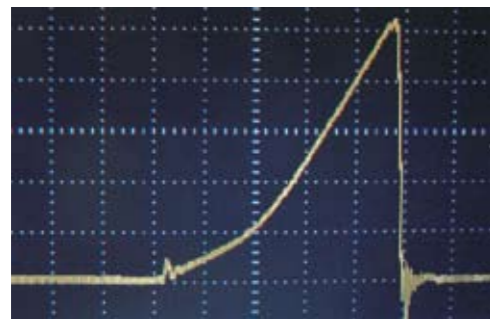

(c)

Figure 6: Primary switch current waveforms for a forward converter with a 15µH off-the-shelf drum core inductor: (a) initial operation, (b) after 60 seconds at room temperature ambient, (c) after 3 minutes operation.

The next experiment used a 15 µH part, with a stated current rating of 9 A. This was also a saturation current, and the continuous dc current was listed as 5 A. The waveforms of Fig. 6 show the results.

Once again, the inductor started out fine with a 4.5 A load, but began to saturate after one minute of operation. In this case, the dc current rating should have been sufficient, but another level of analysis is needed. The inductor design is inadequate for the high frequency ac current imposed upon it, and for this there was no proper specification provided.

Inductor AC Resistance Measurements

The problem of the smaller inductor is clearly illustrated by measuring the frequency dependence of the resistance of the inductor windings. Fig. 7 shows how this resistance changes up to 1 MHz for both the drum core, and the RM8 design.

The dc resistance of the windings for both designs was approximately 55 mOhms. However, at 100 kHz, this rises to 1.6 Ohms for the drum core, and to 100 mOhms for the RM8 core design. In other words, while the dc resistance and inductance of the parts are

the same, the resistance of the small off-the-shelf part is ten times higher at 100 kHz.

The rapid rise of resistance of the drum core design is due to the proximity loss with the multiple layers of windings located in the gap area of the core. [2] The inductor is basically unusable with any appreciable amount of ripple current at the switching frequency.

Summary

By all means take a look at standard off-the-shelf parts when designing power inductors. Be aware, however, that the apparent ratings may greatly overstate the capabilities of the part in your application. You need to dig deep into the data sheets to find out whether that part is truly acceptable in your circuit. If the inductor looks far smaller that you anticipated, it's probably inadequate for the job.

In a rugged power supply, you should never, under any conditions of line, load, and temperature, and transients, see curved waveforms like those shown in this article. Those waveforms indicate failure of the magnetic core material, and will lead to breakdown of the winding insulation, or semiconductor failure.

And finally, if you need the best inductor for your application—go ahead and design it properly yourself. Off-the-shelf parts are optimized for cost in high volume applications, and will rarely be the best solution for your circuit.

Additional Reading

[1] "Power Supply Design Workshop", www.ridleyengineering.com/workshop.htm

[2] "Proximity Loss in Magnetics Windings", Ray Ridley, www.switchingpower-magazine.com/downloads/13 Proximity Loss.pdf

www.ridleyengineering.com

Efficient POWER for your applications



INFINEON TECHNOLOGIES offers a broad range of leading-edge power semiconductors for standardized and application-specific industrial applications such as industrial drives, renewable energies, transportation, power supplies and medical instruments. Our proven chip expertise combined with many years' package know-how enable our customers to select the right solutions for their applications.

www.infineon.com/highpower



Never stop thinking

Measured Winding Resistance

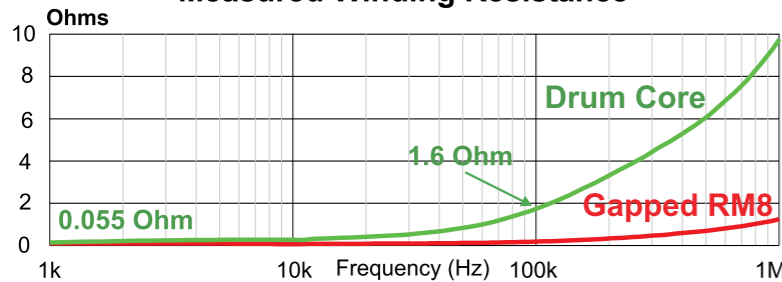

Figure 7: Measured winding resistance of a custom RM8 inductor design, and an off-the-shelf drum-core design.

LEM's New Minisens ASIC Transducer Provides Isolated Current Measurement

Reported by Cliff Keys, Editor-in-Chief, PSDE

With significant pressure applied to designers to produce ever more energy efficient products and in parallel to make products such as white goods quieter and more reliable by replacing the traditional mechanical interlocks and programmers at a lower cost, it seems an impossible task.

Design times are squeezed in every industry with the power side of the design normally being last in the chain after all other requirements have been defined. A flexible, repeatable and easy to design in requirement for current sensing was identified by LEM who, seeing the potential market size, have developed a low cost isolated sensor, **Minisens**, able to monitor currents up to and over 70A.

Minisens is designed for AC and DC isolated current measurement up to 100 KHz. It offers full isolation with no opto-



Caption: Hans Dieter Huber, Vice President, Industry Segment, LEM

couplers required and high sensitivity from 20 mV to 200 mV per Amp of primary current with zero insertion loss. Furthermore, as it is mounted directly

onto a printed circuit board as a normal SMD device, it reduces manufacturing cost.

Minisens integrates within one mixed signal ASIC, Hall-effect sensors and a magnetic concentrator to enable direct current measurement without the need for an additional magnetic core. The non-contact measurement enables an almost unlimited current level as there is no need for current to flow through the device, the only limiting factor being the thermal capacity of the primary conductor. Current to be measured can be carried either by the track located on a PCB underneath the device, or by a cable/ bus bar under or above the IC, providing designers the flexibility for current measurement up to and over 70 Amps.

Calibration is simplicity itself with many parameters of the ASIC configured by on-chip non-volatile memory: adjustment of transducer gain, offset, polarity, temperature drift and gain algorithm (proportional to, or independent of V_{DD}). Two outputs are available: one filtered, to limit the noise bandwidth; and one unfiltered, providing a response time of less than 3 microseconds.

The degree of electrical isolation and output sensitivity can be further enhanced by the PCB design – for example, a primary track on the opposite side of the IC gives highest isolation; a track on the same side gives the highest sensitivity. Mounted as part of a standard PCB assembly process, manufacturing costs are minimized.

During the product launch briefing I



The Best-Selling 2-Channel IGBT Driver Core

The 2SD315AI is a 2-channel driver for IGBTs up to 1700V (optionally up to 3300V). Its gate current capability of $\pm 15A$ is optimized for IGBTs from 200A to 1200A.

The 2SD315AI has been established on the market as an industrial standard for the last four years. The driver has been tried and tested within hundreds of thousands of industrial and traction applications. The calculated MTBF to MIL Hdbk 217F is 10 million hours at 40°C. According to field data, the actual reliability is even higher. The operating temperature is -40°C...+85°C.

The driver is equipped with the award-winning CONCEPT SCALE driver chipset, consisting of the gate driver ASIC IGD001 and the logic-to-driver interface ASIC LDI001.

Chipset Features

- Short-circuit protection
- Supply undervoltage lockout
- Direct or half-bridge mode
- Dead-time generation
- High dv/dt immunity up to 100kV/us
- Transformer interface
- Isolated status feedback
- 5V...15V logic signals
- Schmitt-trigger inputs
- Switching frequency DC to >100kHz
- Duty cycle 0...100%
- Delay time typ. 325ns

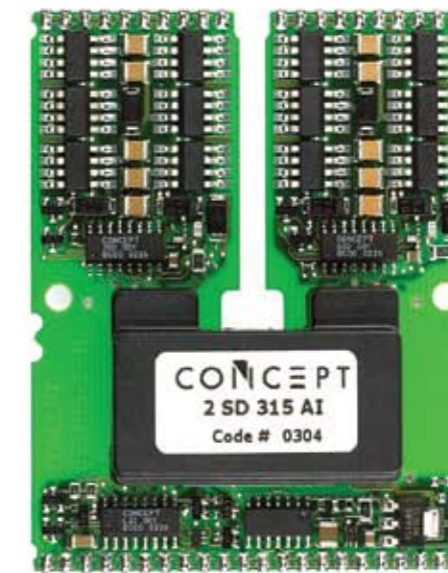

Driver stage for a gate current up to $\pm 15A$ per channel, stabilized by large ceramic capacitors

Specially designed transformers for creepage distances of 21mm between inputs and outputs or between the two channels. Insulating materials to UL V-0. Partial discharge test according IEC270.

Isolated DC/DC power supply with 3W per channel

More information: www.IGBT-Driver.com/go/2SD315AI

CT-Concept Technology Ltd. is the technology leader in the domain of intelligent driver components for MOS-gated power semiconductor devices and can look back on more than 15 years of experience.

Key product families include plug-and-play drivers and universal driver cores for medium- and high-voltage IGBTs, application-specific driver boards and integrated driver circuits (ASICs).

By providing leading-edge solutions and expert professional services, CONCEPT is an essential partner to companies that design systems for power conversion and motion. From custom-specific integrated circuit expertise to the design of megawatt-converters, CONCEPT provides solutions to the toughest challenges confronting engineers who are pushing power to the limits.

As an ideas factory, we set new standards with respect to gate driving powers up to 15W per channel, short transit times of less than 100ns, plug-and-play functionality and unmatched field-proven reliability. In recent years we have developed a series of customized products which are unbeatable in terms of today's technological feasibility.

Our success is based on years of experience, our outstanding know-how as well as the will and motivation of our employees to attain optimum levels of performance and quality. For genuine innovations, CONCEPT has won numerous technology competitions and awards, e.g. the "Swiss Technology Award" for exceptional achievements in the sector of research and technology, and the special prize from ABB Switzerland for the best project in power electronics. This underscores the company's leadership in the sector of power electronics.



CT-Concept Technologie AG
Renferstrasse 15
2504 Biel-Bienne
Switzerland

Tel +41-32-341 41 01
Fax +41-32-341 71 21

Info@IGBT-Driver.com
www.IGBT-Driver.com

Let experts drive your power devices

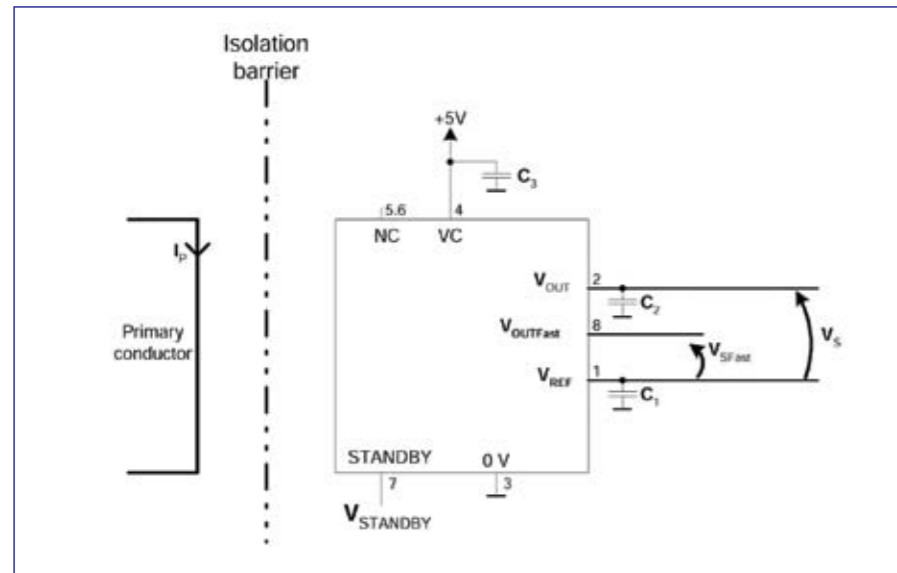

Caption: Typical layout diagram showing the high isolation between conductor and Minisens. With the high accuracy, very small SOIC-8 package, and comprehensive technical design support offered by LEM, a very compact solution can be easily implemented.

took the opportunity to discuss potential markets for Minisens with Hans Dieter Huber, LEM's Vice President for the Industry segment who explained, "The cost and technology benefits of

this completely new approach from LEM has already opened up markets for us in areas such as white goods and air-conditioning. Customers in these areas have found adoption easy with

our comprehensive technical support, evaluation modules and design guides together with the elimination of the more traditional hot and space-hungry shunts."

The combination of different IC configurations and flexible PCB designs results in very versatile and attractively priced current transducer solutions. This opens up opportunities for applications such as white goods or air conditioning to benefit from isolated current measurement, which previously was not feasible. Minisens will also enable enhanced motor control to produce energy savings where other methods such as the shunt have traditionally been necessary with all their incumbent problems of space and heat generation.

Minisens operates from a single 5V supply. To minimize power consumption, an optional input pin can be used to switch the device into standby mode. The transducer is manufactured with a CMOS process and assembled in a SO8-IC package.

www.lem.com

The perfect fit



Delivering exact solutions to fit your company's needs!



Dynex Semiconductor is a global supplier of products and services specialising in the field of power semiconductors and integrated circuit products. Dynex discrete power products are used to improve the efficiency, reliability and quality of the electric power in;



- Power transmission and distribution
- Renewable power generation
- Marine and propulsion systems
- Medical equipment
- GTO: 1300v to 6500v, 600A to 4000A
- Heavy industries such as steel and mining
- Thyristors: 1200v to 8500v, 450A to 6000A
- Diodes: 60v to 600v, 900A to 8000A

Designed to meet the most rigorous performance requirements in the market.

dynexsemi.com



50 YEARS OF SEMICONDUCTOR PRODUCTION IN LINCOLN

T: +44 (0)1522 502901
 F: ++44 (0)1522 500020
 E: power_solutions@dynexsemi.com

Power Supply Design Workshop

Gain a lifetime of design experience . . . in four days.

Dr. Ray Ridley's laboratory workshops are expanding into Europe in 2007. In our four-day workshops, you'll build and measure switching power supply circuits in a state-of-the-art lab. Our practical, hands-on approach teaches engineers with all levels of experience how to be more efficient designers. Learn how to use POWER 4-5-6, the world's most comprehensive software.

Only 24 seats are available at each workshop. Tuition includes training, lab notes, POWER 4-5-6 software, and lunch. Download a reservation form at www.ridleyengineering.com.

2007 Schedule

Feb 5 - 8	Atlanta, Georgia US
Apr 16 - 19	Atlanta, Georgia US
Jun 4 - 7	Bordeaux, France
Jun 11 - 14	Munich, Germany
Sep 10 - 13	Atlanta, Georgia US
Nov 5 - 8	Atlanta, Georgia US

Frequency Response Analyzer

The NEW AP300 from AP Instruments

The AP300 is an essential tool to ensure stability and design integrity in switching power supplies.

The AP300 makes swept frequency response measurements that give magnitude and phase data plotted versus frequency.

30MHz

Ridley Engineering, Inc.

www.ridleyengineering.com

In the US: 885 Woodstock Rd. Suite 430-382 Roswell, GA 30075 US +1 770 640 9024
 In the UK: 10 The Green Bracknell, Berkshire RG127BG England +44 1344 482 493

Frequency Range	0.01 Hz to 30 MHz
Selectivity Bandwidth	1 Hz to 1 kHz
Output	20V p-p at 2 Ω
Injection Isolator	Optional 0.1 Hz to 30 MHz
Input Isolation	Optional 1,000 V
PC Data Interface	High-speed USB 2.0



Maxwell Ultracapacitors Help P21 GmbH Provide Fuel Cell-Based Backup Power for Telecoms

Many advantages over battery back-up systems

While fuel cells are an excellent technology for backup power, they take a few seconds to come online and provide full power. P21 therefore needed to select an energy storage technology to provide short-term "bridge" power to cover this gap.

Reported by Cliff Keys, Editor-in-Chief, PSDE

P21 GmbH, based in Germany, develops, produces, and sells fuel cell based backup systems. They are used in base station networks where conventional batteries often operate at their technical limits. With its patented, hydrogen-powered PEM fuel cells, P21 is the leading supplier of fuel cell power for use in the telecommunications industry: as backup solutions, primary supply in combination with renewable energies, energy saving systems with unattended remote control operation

Requirements for backup power in telecoms

For many mission-critical installations, backup power generation equipment is essential to ensure continuous operation. The telecoms industry, in particular, needs to ensure that its mobile phone base stations have power at all times, and are able to keep functioning even if there is an interruption to the grid electricity supply.

Traditionally, the technology chosen for back up power was batteries. More recently, fuel cells have been used for base station power backup. PEM (Proton Exchange Membrane) fuel cells are today highly-efficient energy conversion devices that can operate continuously

for as long as hydrogen is available. They are environmentally benign and can provide a reliable source of back-up power for many applications. They provide high reliability and savings in cost, space and weight, and can withstand harsh conditions of high temperatures and humidity. P21 fuel cell systems have advanced control and online monitoring features, to ensure they are safe in operation.

Fuel cells have proven reliable in practice, with over 1 billion hours of operation over 10 years in back-up power applications. Based on a 10-15 year useful life a fuel cell based solution can be around 30% less expensive than a battery backup solution.

However, a typical P21 fuel cell has a start up time of about 5 seconds to achieve full power. This means that a short-term source of bridge power is still required to ensure continuous operation.

While batteries have often been used with fuel cells to provide this bridge power, they have a number of disadvantages, including relatively short lifetime, regular maintenance requirements, and poor performance in extreme temperatures. For long-lasting, reliable applications this means there is a higher

maintenance cost, and concerns about reliability.

Ultracaps in backup power solution

P21 decided to investigate other energy storage solutions that could be used instead of batteries. They chose ultracapacitors, which are an excellent match to work with fuel cells. With low ESR and high charge storage capacity, ultracapacitors can ramp up large currents with minimal change in voltage, creating a short-term buffering response to peak power demands. They smoothly deliver power through transient interruptions. This permits the fuel cell to maintain its quiescent operating point without inefficiency. This combination results in an energy rich, reliable, maintenance free solution that is also very environmentally friendly.

"Ultracapacitors were selected because of their reliability, load/duty cycle stability and because they are maintenance free," said Dieter Braechtken, CEO of P21 GmbH. Maxwell's ultracapacitors have a lifetime of typically over a million cycles, making them well-suited to this application.

Ultracapacitors have another advantage over batteries that makes them

2007

China's platform for the electronics community

Components and Assemblies & Production Technologies



electronica & Productronica China 2007

With PCIM China

Featuring LASER. World of Photonics China

Collocated with Semicon China and CPCA Show

March 21–23, 2007

Shanghai New International Expo Centre SNIEC

Contact:
Messe München GmbH
Tel. (+49 89) 9 49-2 03 25
Fax (+49 89) 9 49-97 2 03 25
info@global-electronics.net

www.global-electronics.net



Global
electronics

suited to support fuel cells in backup applications. A fuel cell's output varies with load. A battery's output is fairly fixed, and will affect the fuel cell's performance. An ultracapacitor, however, has no fixed operating voltage, and therefore can operate directly across the output of the fuel cell, directly into the power electronics.

Ultracapacitor technology and benefits

Also known as supercapacitors or Electrochemical Double Layer Capacitors (ELDC), ultracapacitors are not a new component, but the technology has advanced dramatically in the last 5-10 years.

The beneficial characteristics of ultracapacitors are made possible by their composition and construction. Their activated carbon electrode has a specific surface area of 2000m²/g with a charge separation of 10 Angstrom or less, giving them a very high capacitance. High conductivity electrolytes, a proprietary electrode manufacturing techniques and an advanced cell design allow ultra-low internal resistance and thus highest power density products. The energy storage mechanism is highly reversible, with no chemical bonds being made or broken, leading to a cycle life of over 1 million cycles with minimal degradation. The operating temperature domain is between -40degC and +65degC, or even higher for short durations.



Figure 1: Maxwell BMOD0058 and BPAK0058 ultracapacitor modules for bridge power applications

With the maturity of the ultracapacitor industry, ultracapacitors are highly competitive with, and in many cases superior to, older bridge technologies. They offer the functionality, life cycle costs, and reliability necessary to make mission-critical power backup systems

successful. Since the ultracapacitor is used strictly as a bridge, its high power density is well suited to supply high power for short periods up to 30 seconds. A battery is more typically sized to deliver power over longer periods, making them larger than necessary in case of bridge power applications. If a battery is sized for the actual short duration required, it may have difficulty supplying the necessary power.

One key challenge with batteries is the difficulty in measuring their state of charge and their state of health. The charge of an ultracapacitor, however, is measured solely by its voltage. The measurement of the capacitors charge and internal resistance allows to determine the state of health. A simple and direct monitoring of the energy storage system is thus guaranteed. Additionally, since ultracapacitors operate on a different principle than batteries, the ultracapacitor is capable of sitting on a charge voltage for extended periods without any loss of capacity, unlike a battery.

Furthermore, cycle depth isn't an issue, so ultracapacitors can be micro-cycled (cycled less than 5% of their total energy) or full-cycled (cycled greater than 80% of their total energy) with the same long life.

Ultracapacitors are inherently reliable because of their composition and construction. There are no mechanical moving parts as in a flywheel, eliminating all maintenance. Combined with the wide temperature range, long life, and flexible voltage range, ultracapacitors provide an extremely reliable solution for bridge power.

P21's Premion T system

P21's Premion T fuel cell products, which incorporate ultracapacitors and fuel cells, have been developed specifically for the needs of the telecoms industry. Compared with conventional batteries they guarantee completely flexible backup times, are substantially more cost-efficient and reliable, significantly lower maintenance efforts and longer life and are much more environmentally friendly because of the use of hydrogen to generate electricity. The fuel cell systems also reduce energy costs due to reduced air conditioning

requirements, and total cost savings of more than 30% can be achieved over the whole lifecycle.

For UPS applications in telecoms, Figure 2 shows a typical backup system with battery, while the layout of a backup system including Premion T is shown in Figure 3.

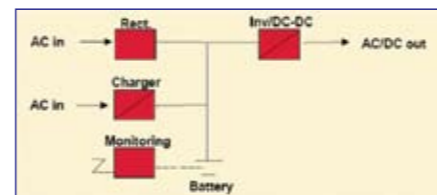

Figure 2: layout of a typical backup system with battery.

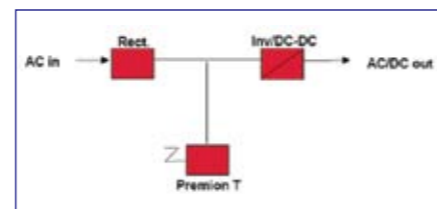

Figure 3: layout of a typical backup system with Premion T fuel cell system.

The Premion T system is housed in a 19" rack and weighs 93kg. It delivers 3kW output power. It is extremely reliable, and thus ensures the high availability of the systems it is protecting. Typical lifetime in backup systems is 10-15 years.

To help ensure this level of reliability, Premion T includes sophisticated monitoring software, error logging and remote maintenance capabilities. The monitoring software can be used to show the operation of the ultracapacitors. Firstly, Figure 4 shows Premion T on standby, with the ultracapacitors fully charged from network power, at voltage of 54V.

Then, Figure 5 shows what happens when the grid loses power and the Premion T starts to provide backup power. This is immediately after the grid power has gone down, and before the fuel cells are online. The ultracapacitors can be seen to deliver 1680W, maintaining system operation.

Finally, Figure 6 shows the fuel cell system starting up and providing power

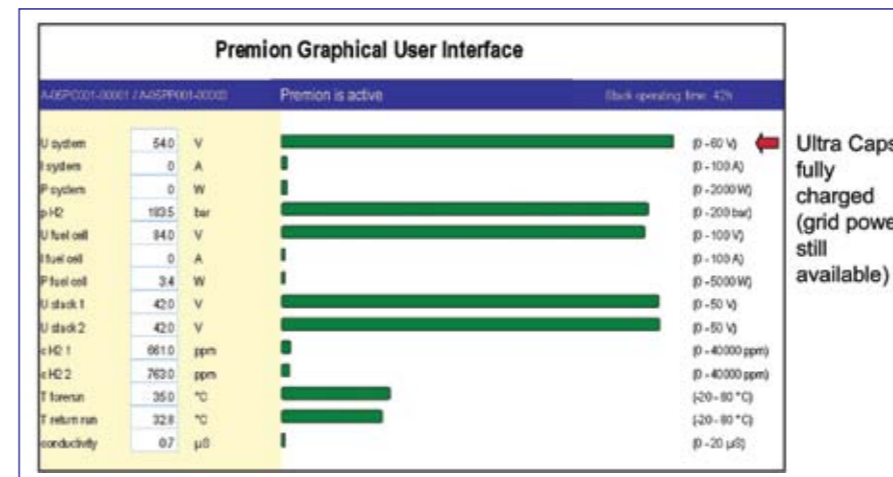

Figure 4: Premion T on standby.

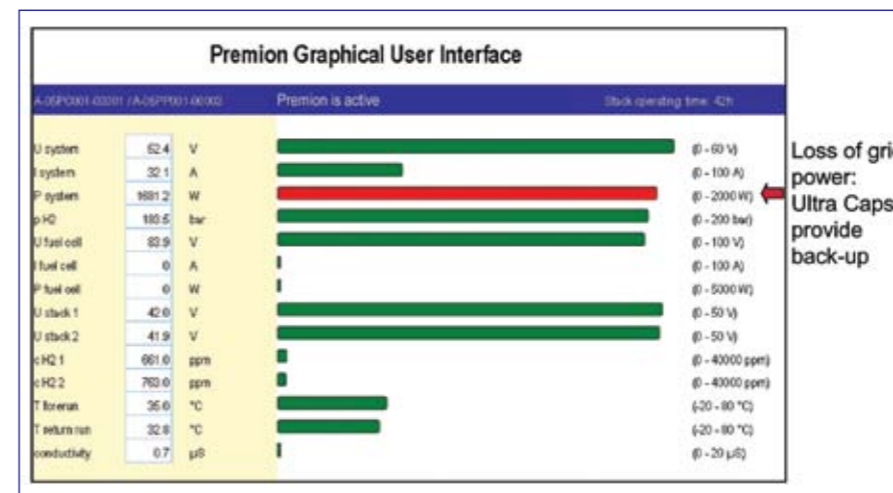

Figure 5: Ultracapacitors providing back-up power.

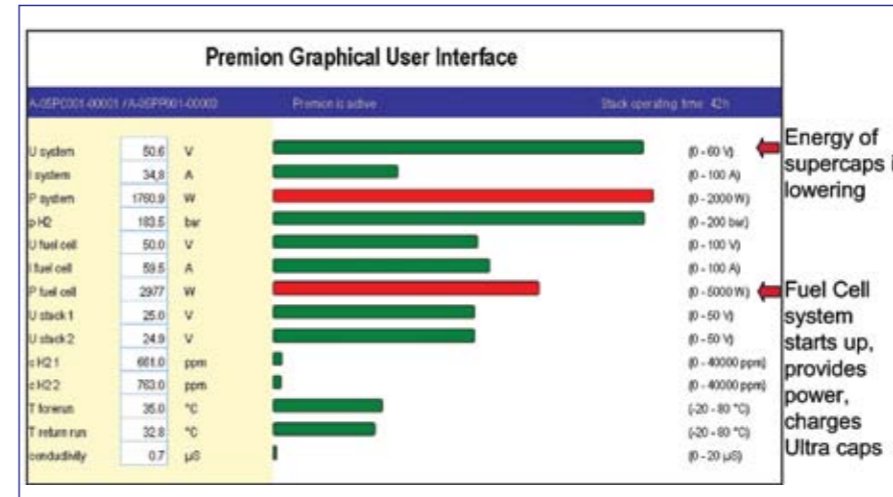

Figure 6: Fuel cells providing power.

for the system. The energy stored in the ultracapacitors has reduced, but the fuel cells are now able to recharge the ultracapacitors.

As well as ensuring continuous power

during grid blackouts, the ultracapacitors also serve peak load requirements during fuel cell operation.

Working with Maxwell Technologies

"The important factors that led us to

choose Maxwell are the availability of the product, its quality and the availability of different packaging options," said Dieter Braechtken. Maxwell's BOOST-CAP ultracapacitors can be solder-connected and thus easily integrated into P21's proprietary high-power electronic circuit boards.

The Premion project was started in 2002, and the first prototype was created by the end of the year. First shipments to customers were in 2003, and Maxwell's ultracapacitors have been proven to work successfully in P21's Premion products and prototypes in different product generations.

While the main focus of P21 is telecoms basestations, the Premion T has also proven to work well in different kinds of critical IT and communication applications and the range of applications and product options is steadily being extended. "P21 is working to broaden the application range of the Premion T product and ramping up production," said Dieter Braechtken.

P21 has worked both directly with Maxwell, and with their German distributor Alfatec GmbH. "We have always been well-supported on the technical and commercial level. The response times were short and the information provided was helpful," said Dieter Braechtken.

Conclusions

Working with fuel cells, ultracapacitors are a valuable component for backup power applications, because they are reliable and maintenance-free, able to operate at extreme temperatures, and have a long operating lifetime.

P21 has designed an innovative backup power system for telecoms applications that takes full advantage of these features, and performs significantly better than battery-based alternatives.

"The ultracapacitors are an important feature to enable P21 to provide the benefits of our fuel cell systems to our customers," concluded Dieter Braechtken.

www.p-21.de

www.maxwell.com

Power Electronics Upgrades Fluorescent Lighting

Magnetic ballasts replaced in the dominant industry light-source

The main reason for replacing the iron cored 50/60Hz transformer or ballast is energy efficiency. Depending on the application, the return on investment when replacing magnetic with electronic ballasts can be as short as one year.

By Dr. Michael Weirich, The Global Power Resource Center Europe, Fairchild Semiconductor, Fuerstenfeldbruck, Germany

Today more and more lighting applications make use of electronics. Low voltage halogen lamps are driven by electronic transformers; the classic magnetic ballast for fluorescent lighting is replaced by the electronic ballast and the new high power high efficacy LEDs are driven by switched mode current sources. The main reason for replacing the iron cored 50/60Hz transformer or ballast is energy efficiency. At the same time, an electronic ballast gives higher performance and comfort at lower weight and volume, a great advantage in state-of-the art fixtures and designer lamps. Although in domestic applications, the incandescent lamp – mainly in the form of halogen lamps – is still used most often, in professional applications like office lighting, the fluorescent lamp still dominates.

Fluorescent Lighting and Electronic Ballast

A fluorescent lamp (FL) consists of a glass tube with filaments at both ends, filled with low pressure noble (inert) gas and, as active component, mercury vapour. A current flow through this gas

excites the mercury to emit invisible ultraviolet light. The ultraviolet radiation is converted into visible light by means of the phosphor coating of the tube. Prior to a current flow, the gas has to be ionized by applying a high ignition voltage. After ignition, the ionized state is maintained by the continuous current flow. Ignition of the lamp is much easier and lifetime is considerably increased by preheating the filaments to at least 600 – 700 °C. The gas discharge has negative differential resistance, i.e., current increases while operating voltage drops. Consequently, any gas discharge needs a current limiting element in a series. The classic magnetic ballast together with the starter as shown in Fig. 1 perfectly implements the requirements to operate a fluorescent lamp. Initially, the starter switch S1 is closed and a current flows through L1 and the filaments of the lamp. When the starter opens after a certain time – how this is implemented is beyond the scope of this article – the filaments are at high temperature and the abrupt change in current induces a high voltage in the inductor and across the lamp. After ignition the impedance of the inductor

limits the discharge current.

Some disadvantages of this simple ballast are obvious, others not. First the starter switch may open close to zero crossing of the line voltage. Current flow is small at this time and the same is true for the ignition voltage. The lamp may not strike and one can easily identify a magnetic ballast by recognizing several attempts to start the lamp. A less obvious disadvantage is the poor system efficiency due to two reasons. Firstly, for the sake of cost, a high loss in the inductor itself is accepted. Secondly, the ions in the discharge recombine during zero crossing of the line voltage and have to be re-ionized in the next half-cycle. The latter effect results in considerable loss of energy.

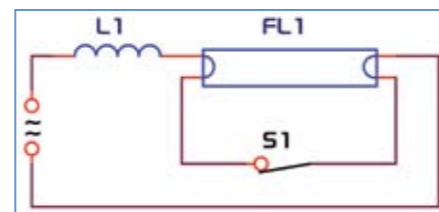

Figure 1: Magnetic FL ballast with starter.

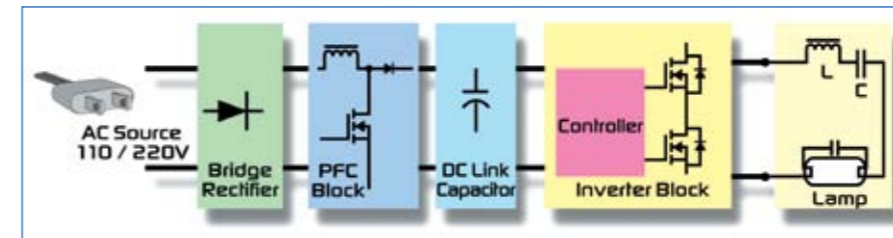

Figure 2: Block diagram of a professional FL ballast.

One of the main advantages of the electronic ballast is that the lamp is driven with a much higher frequency of 30 – 60 kHz typically. Due to this higher frequency, the recombination of ions does not happen and the efficacy of the lamp itself increases about 10% compared to operation at 50/60Hz. Moreover the electronic ballast itself is designed to achieve efficiency of more than 90% and together with state of the art high efficiency FL (so-called T5 lamps) the energy savings can easily achieve 30% compared to magnetic ballast at line frequency. Consequently the European standard EN 50294 lists four efficiency classes of magnetic ballast and according to directive 2000/55/EG the class D with 'very high' losses has been abandoned since 2002 and class C with 'moderate losses' since 2005.

Fluorescent lamp technologies are classified according to their diameter in multiples of 1/8 of an inch e.g. T8 means a Tube with 8/8 inches (~ 26mm) diameter. While in most domestic applications in Europe the T8 fluorescent lamp is still used, normally in professional applications the T5 lamp is used. For the latter, operation with magnetic ballast is not now specified within the standards.

Other advantages that electronic ballasts may have are 'perfect' preheating of the filaments (making the lifetime of the lamp virtually independent of the number of switching cycles), flicker free start and operation, constant light output with variable input voltage and high power factor. Finally, and important for emergency lighting, the electronic ballast can be operated with DC input voltage i.e. from batteries.

The topology for the FL ballast most popular in Europe is the voltage fed series resonant half-bridge shown in Fig. 2.

The half bridge is driven with variable frequency and a duty cycle close to 50%. At startup, as long as the FL is not ignited, the ballast controller generates a frequency well above the resonant frequency of L_1/C_1 . Thus, a high current flows through the lamp filaments heating them up to the desired temperature. After a time, normally determined by external components, the controller starts to lower the operating frequency towards resonance. A high voltage across the lamp is generated as a result and the lamp will ignite. After ignition the impedance of the FL damps the resonant circuit fairly well and the voltage across the lamp drops close to the operating voltage. In most applications the lamp current is sensed directly or indirectly and the operating frequency is adjusted until the set-point is met. As long as the operating frequency is above the resonant frequency of L_1/C_1 , the MOSFETs are soft switched and switching losses are

negligible while at the same time EMI is reduced.

MOSFETs with fast recovery body diode (FRFET™) are perfectly suited for this application as already shown in (1). There are 500V and 600V Q-FET™ available with fast body diode as well as 600V SuperFET™. Since the gate of the upper MOSFET needs high voltage drive, a high side gate driver is needed. The high voltage drivers, FAN7380, FAN7383 and FAN7384 as well as in some of the FAN7382, implement all these needs with best-in-class noise immunity. Finally there are pure ballast controllers like the FAN7544 that implement the control and safety functions as well as controllers with integrated high voltage gate drive such as the FAN7532.

Power Factor Correction

Current international standards demand for power factor correction in lighting equipment if the consumed power is above 25W. This is for two reasons: One is that the classical incandescent bulb behaves like a resistor i.e., voltage and current are in phase. The second is that lighting consumes 10 – 12% of the total power produced and is normally in operation for several hours a day, quite long compared to other equipment. Consequently, if lighting electronics was

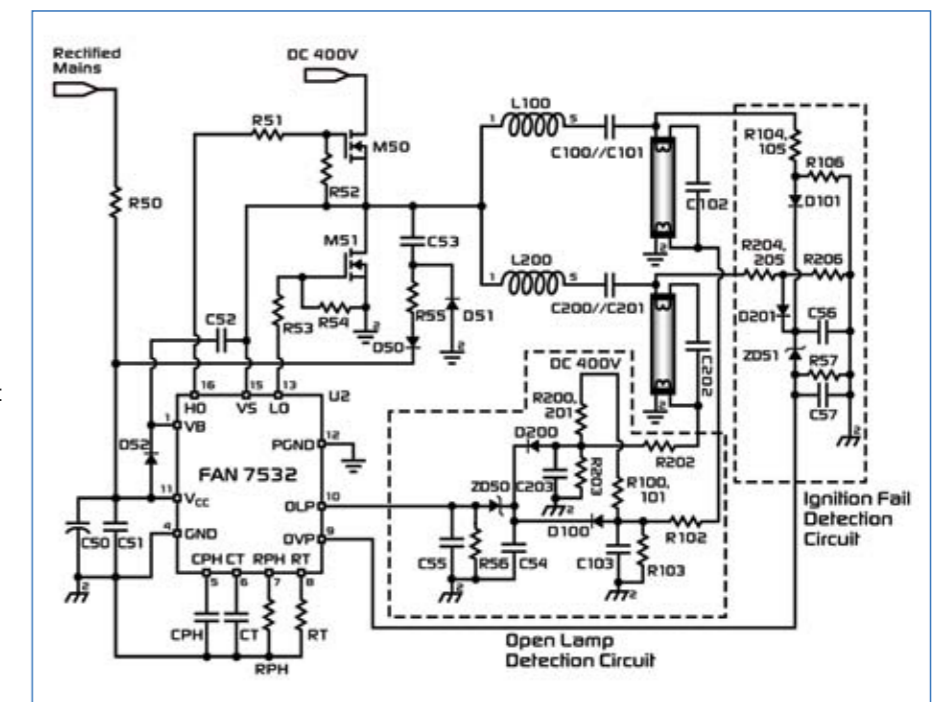

Figure 3: Typical Ballast Application with FAN7532.

not power factor corrected, this would cause significant additional losses in the power grid.

Since most fixtures have a total power below 150W, critical (or boundary or transition) mode PFC is the most economic solution. In this mode the peak current through the inductor is controlled such, that this peak value is proportional to the rectified input voltage. During off-time, the inductor current falls back to zero. Zero crossing of the current i.e. de-magnetization of the inductor, initiates the next switching cycle. It is easy to see that the average inductor current is proportional to the input voltage - the desired result. There are two different approaches to control the peak inductor current. In the so-called current mode as implemented in the FAN7527, the rectified line voltage is sensed to generate the current reference that sets the actual value of the peak current. The necessary divider network can cause considerable loss, something that ballast designers badly try to avoid. In voltage or constant on-time mode implemented with the FAN7529,

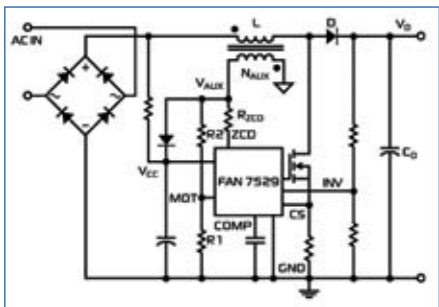

Figure 4: Typical application diagram for voltage mode control of transition mode PFC.

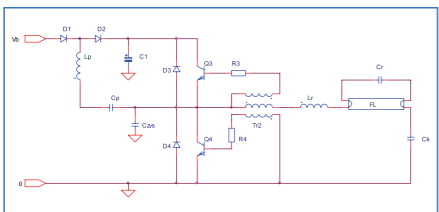

Figure 5: FL ballast with charge pump PFC (Lp and Cp).

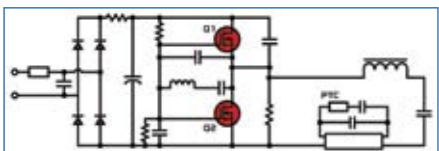

Figure 6: Typical self oscillating CFL ballast.

the on time of the switching device is kept constant during one or more line half-cycles. Keeping on-time constant, peak switch current is again proportional to input voltage as can be easily derived from the basic differential equation $di/dt = V/L$. Common to both modes is the sensing and regulation of the output voltage.

In a low-cost ballast, one may find different PFC topologies. Either a high inductance value iron core choke is used to smooth input current or, more often, the power switch and the control IC are omitted and a so called charge-pump PFC is used. In this topology the half-bridge is used to drive the fluorescent lamp and the PFC at the same time as shown in Fig. 4. Since the lamp power has to be regulated and there is no additional degree of freedom that could be used to control the PFC, it is very difficult to find proper L and C values that result in good power factor and stable lamp operation over a wider input voltage range. That is the main reason why this topology is not used more often, though it is an inexpensive solution.

End of Lamp Life Detection

In a gas discharge there is a region close to the cathode where the discharge voltage drops steeply and no light is emitted, the so called 'Cathode Fall'. Due to the voltage drop and the current flow there is a certain amount of power dissipated in this region. With increasing operating time, the filaments of the lamp become less and less emissive and the cathode fall increases. In turn, the power dissipation close to the cathode increases and this region of the lamp is heated up more and more. If the diameter of the lamp-tube is small, it could be heated up to melting point. Therefore, the thinner the tube, the more important is a feature called EOL (End of Lamp Life) detection. Especially for

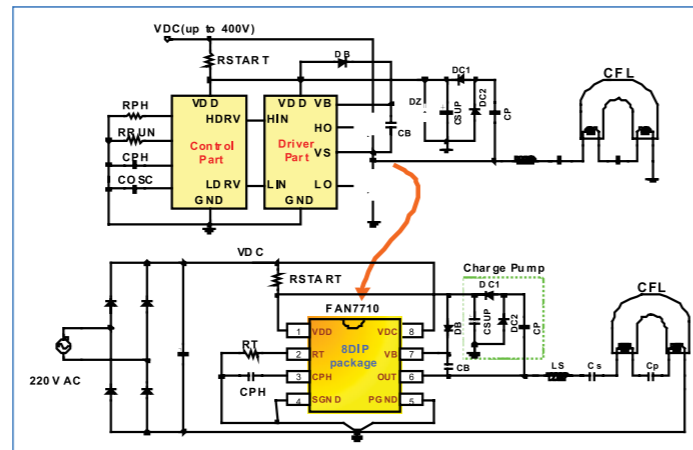

Figure 7: Typical CFL ballast application with FAN7710.

T5 this feature is indispensable and contained within the European safety standards for fluorescent lighting.

Normally the FL is operated with AC and each filament is the cathode for 50% of the time. Fortunately one of the two filaments will lose emissivity first and lamp behaviour becomes asymmetrical. Thus, it is possible to detect EOL by e.g., monitoring overall lamp voltage or symmetry of operating voltage or current.

Compact Fluorescent Lamps (CFL)

CFL contain an electronic ballast integrated with the lamp. Since these replace incandescent bulbs, traditionally they are thrown away after FL is defect. That's why the electronic of a CFL does not need to have the extraordinary long lifetime of a FL ballast (up to 50.000h). In addition, the power is limited due to limited space and PFC omitted. Altogether, while having the same basic structure, the CFL uses a slightly different inverter circuit compared to the FL ballast. Instead of a control IC most CFL still use a self oscillating half bridge as shown in the Fig. 5

Newer integrated circuits like the FAN7711 controller, high voltage gate driver as well as the FAN7710 with additionally integrated Power MOSFETs, help to simplify the design of CFL while being cost-competitive. This is especially true if additional performance and safety features implemented by the integrated controllers are considered.

www.fairchildsemi.com

Power Management Ramp Rate Control with a Mixed-Signal FPGA

Complexity of board-level power supply management means designers need a flexible, "live-at power-up" power system management master

The mixed-signal FPGA, with its analog quad analog I/O structure and analog-to-digital converter, represents a smart, simple and flexible solution for power sequencing and ramp-rate control. This capability is necessary to ensure proper operation of the system's processing devices, including DSPs, microprocessors and SRAM FPGAs.

By Rich Howell, Senior Product Marketing Manager, Actel Corporation

As process geometries shrink, devices often require multiple power supplies. Device cores tend to run at lower voltages to reduce power and maximize performance. To interface to legacy devices or to comply with existing I/O standards, I/O voltages run at voltages different from and typically higher than the core. Often devices support multiple I/O banks, each running at a different voltage level (1.8V, 2.5V, or 3.3V). In order to reconfigure or reprogram devices, it is common to support yet another power rail. Certainly, the interrelationships between these power rails and the increase in total number greatly increase the complexity of board-level power supply management.

Designs with field-programmable gate arrays (FPGAs), digital signal processors (DSPs), and application-specific integrated circuits (ASICs) can demand four, five, or even more power supplies to

power up in a prescribed sequence and ramp-rate in order to avoid issues such as latch-up, inrush current, or I/O contention. Additionally, many applications require adjustable power-up sequencing and ramp-rates to accommodate various scenarios.

To fulfill the requirements in these applications, a power system management master must be live at power-up in order to sample and monitor multi-channel analog voltage inputs. Based on the system requirements, the master sequences multiple power supplies at the appropriate ramp-rates. The master also has the flexibility to adjust to a different sequencing and ramp-rate and can remember the previous parameters used in sequencing and ramp-rate control.

A live at power-up mixed-signal FPGA can offers many benefits to this

type of power management control. These FPGAs integrate large blocks of embedded flash memory, programmable logic and configurable analog in a single monolithic device. By integrating large blocks of flash memory, the programmable system chips enable designers to implement a wide range of tasks, including recording system performance history, updating operating parameters, monitoring system parameters to predict failures before they occur (prognostics), EEPROM emulation, and boot code storage. Beyond simple power management, these devices can also be used to control supply voltage ramp rate. The analog system can be configured to sample and monitor up to 30 channels of analog signals and control up to 10 gate drivers with programmable drive strengths that control sequence and ramp-rates of multiple power supplies.

To use the programmable gate drivers

Shrinking the Power Management Footprint

Moore's law does not work in analog

Shrinking analog power management circuitry hasn't been as straight forward as in digital technology. Even so, tremendous advances have been made recently in both linear regulators and switchers.

By Ralf Muenster, Director of Marketing, Power Products, Micrel Inc

Cell phones are shaping up to become the ultimate wireless gadget, a combination of video phone, PDA, GPS navigation system, digital still and video camera as well as portable entertainment system.

Not too long ago cell phones were bulky single function, voice centric devices with tiny alpha numeric greenish displays that were heavy and uncomfortable to be carried around in any pocket or purse. People were seen having mounted them on their belts or arranging them next to their plates and silver ware in restaurants; not so much too show-off their gadgets but out of pure necessity since they were pinching and bulging their garments.

This picture has changed dramatically. New cell phone models have become feature packed lightweights with vibrant color displays, slim enough to slip unnoticed into the front pocket of the tightest jeans. Cell phones now feature powerful high definition digital still and video cameras with flash LEDs that brighten the darkest night. The high resolution displays are large enough to screen your emails on the fly or watch the latest blockbuster movie during a long flight. The sound quality parallels your iPods and removable miniature flash cards with more than 4GByte of memory allow carrying along complete CD collections. Digital terrestrial and satellite TV reception promise entertainment while riding home from work in the subway. The consumer's wide acceptance of these

new features has encouraged wireless providers to invest in upgrading their networks. This will allow providers to take advantage of the next generation wireless standards such as EDGE for GSM networks and HSDPA for WCDMA networks which allow for download speeds in the range of 1Gb/sec making video telephony the standard ultimately.

These trends present immense challenges but pose also opportunities for cell phone manufacturers to come out with differentiated, ever more densely packed designs in stylish new form factors. They in turn rely on the help of digital and analog semiconductor power houses to support them in this quest for miniaturization.

Shrinking digital circuits has been fairly straight forward and well understood. Already in the 70s Moore's law postulated the doubling of transistor density every 24 months. Digital semiconductor companies achieve this by marching down a steady but costly path to smaller and smaller process geometries that allow them to pack more gates on a chip.

Shrinking analog power management circuitry on the other

hand hasn't been as straight forward but significant advances have been made recently in both linear regulators and switchers.

Linear regulators have been dominating portable designs for the longest time due to their cost, ease of use, low solution component count, straight forward board layout and low noise. While people have been predicting the demise of low-drop-out (LDO) linear regulators in cell phones they continue to survive and even thrive because there continue to be significant advances. Engineers who design linear regulators are doing their part to help portable products continue shrinking. Packages continue to get smaller while performance specs get better. Advances trim the overall size by squeezing LDOs into smaller and smaller packages or by incorporating

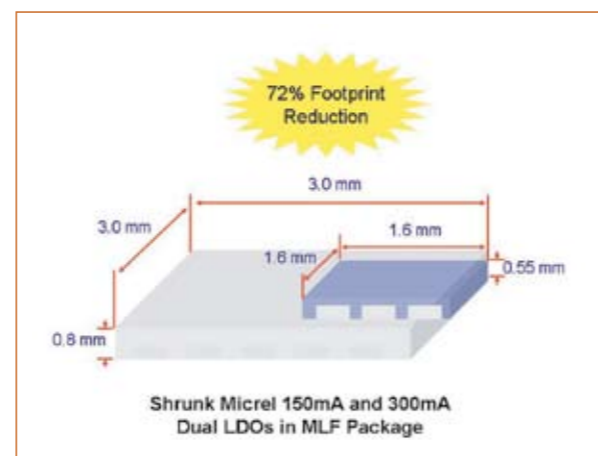

Figure 1: Micrel has managed to shrink the footprint of 150mA and 300mA Dual LDOs packages by 72%.

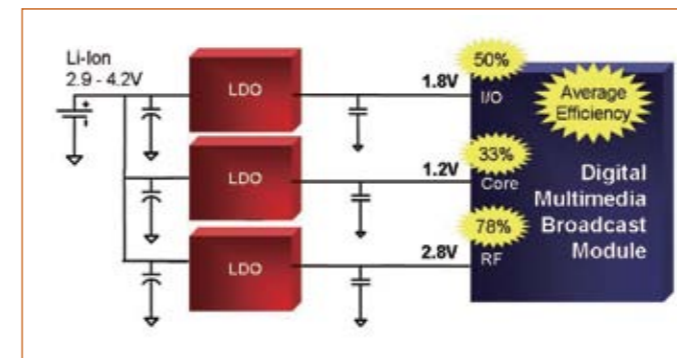

Figure 2: The three input power rails of a digital multimedia broadcast module (DMB) powered by three LDOs and corresponding average efficiencies for every rail.

functions so fewer or smaller external parts are needed.

Micrel has recently managed to package dual ultra-low dropout voltage (ULDO™) linear regulators in a 1.6 x 1.6 x 0.55 mm 6-pin MLF package. Despite their small size, the parts have ultra-low dropout voltages of 35mV and 70mV at 150mA and 300mA, respectively, and more than 70 db Power Supply Rejection Ratio. Engineers can reduce the footprint of their systems by 72 percent compared to standard 3 x 3 mm packages (Figure 1). The latest member of this family is the MIC5335, a dual 300mA ULDO™ that sets a new industry benchmark for current density delivering up 234 mA per square mm making possible very compact form factor designs. The parts feature low quiescent current, a fast turn-on time of 30 μsec, current limit and thermal shutdown protection, and can operate from -40 to 125C. Moreover, the ICs offer excellent transient performance in spite of using only tiny 1uF caps and the industry's lowest dropout for a 300 mA LDO, enabling longer battery life in portable applications with a Li-Ion battery.

For hardware engineers that are looking to use a single LDO only, Micrel now sells single 150mA and 300mA ultra-low dropout voltage linear regulators in a 1.2 x 1.6 x 0.55 mm 4-pin MLF package. This is currently the smallest available LDO package and parallels the form factor of bumped dies without the drawbacks in manufacturability and the low thermal performance.

As cell phones integrate more functions and people use their cell phones

presents significant new challenges.

While LDOs are small, cheap and easy to use they are unfortunately not very energy efficient as soon as the input and output voltage differential is larger than a few hundred milli-Volts. With linear devices the conversion efficiency is determined by the ratio of output voltage they're set to provide over input voltage. Typically these devices are connected directly to the Li-Ion battery in a cell phone which provides anywhere from 2.9 to 4.2V. Generating core and I/O voltages for today's deep submicron digital chips like the graphics accelerator, terrestrial or satellite TV receiver modules or application processors quickly yields conversion efficiencies well below 50%. Figure 2 shows three digital multimedia broadcast module input power rails powered by three LDOs and the corresponding average efficiencies for every rail.

DC-to-DC switching regulators on the other hand can provide a very efficient means of translating between two DC voltages even if the input and output differentials are large. Conversion efficiencies in the 90-95% range are common. Aside of longer battery life, the higher efficiency means also less heat dissipation allowing for denser component packing in these space constraint ap-

more frequently and for longer periods, more power is consumed by both active and stand-by systems. Consequently, as designers are trying to maximize battery life without increasing the battery size, power management design for portable devices

plications.

So why have switching regulators not completely taken over cell phone applications yet?

For one, switching regulator solutions are more costly, use up more space and generate more noise than linear regulators. Therefore they can be a challenge in terms of noise, cost and space-sensitive cell phone designs.

Moreover, switching regulators have a larger footprint than linear regulators because they need a bulky inductor and also a larger output capacitor. Figure 3 gives a comparison between the circuitry of a linear regulator and a

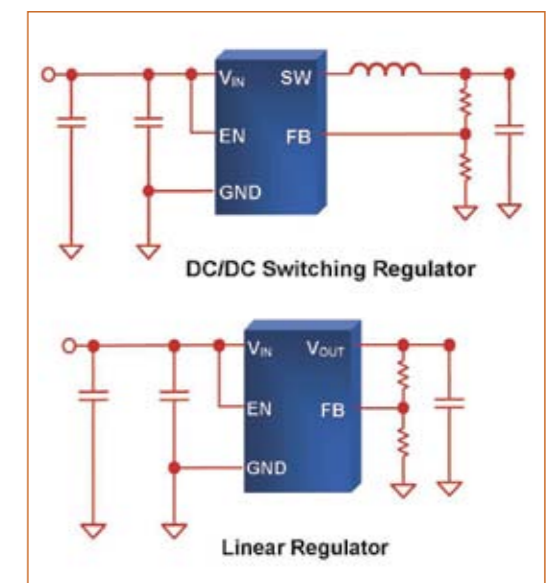

Figure 3: Typical Circuits for Adjustable Output DC-to-DC Switching and Linear Regulators.

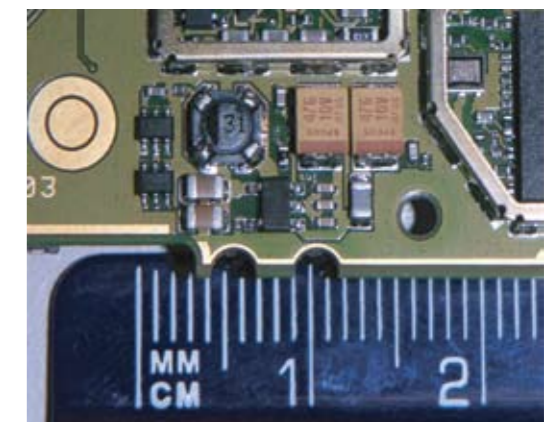

Figure 4: Industry standard SOT-23-5 buck regulator with winding coil inductor and large tantalum capacitor. The complete solution size is just ~140mm².

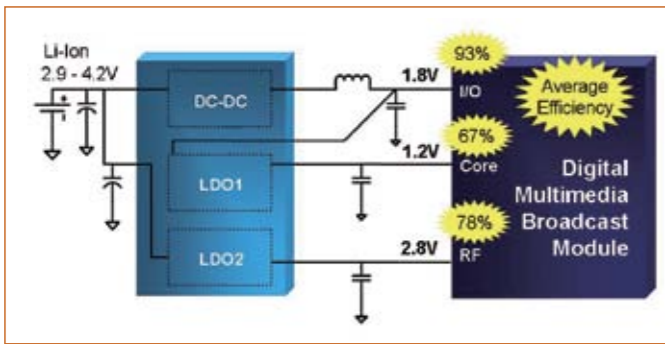

Figure 5: The three digital multimedia broadcast module input power rails powered by Micrel's MIC2800 high efficiency switcher and low input voltage LDO combination and the corresponding average efficiencies for every rail.

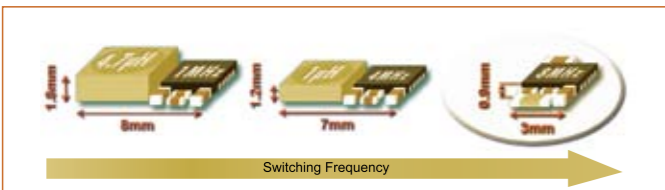

Figure 6. Solution Size and Height Comparison with Increasing Switching Frequency.

buck switching regulator and Figure 4 shows a standard solution footprint for a switching regulator in a cell phone design using a standard SOT-23 package and a winding coil inductor. As can be seen, the inductor and output capacitor dominate the solution size. The solution is 10mm x 14mm out of which the inductor alone is ~ 4mm x 4mm.

The compromise

A good tradeoff between efficiency, cost, and solution size is the combination of advanced switching regulators with low input voltage LDOs. Micrel has recently demonstrated a highly efficient, flexible power management IC that provides three voltage outputs, one switched and two LDOs, plus a power on reset in a tiny 3mm x 3mm 16 pin MLF™ package. The high efficiency 2MHz DC-to DC switching regulator on this chip provides up to 600mA and delivers more than 93 percent efficiency. The switcher only requires tiny 2.2uF output capacitor and a 2.2uH inductor for stability. The big advantage of this ensemble is that one of the linear regulators works from a low input voltage, allowing it to post-regulate the switching regulator for maximum efficiency. For the previous DMB example, the high speed DC/DC converter can step down the Li-Ion battery input to 1.8V

and the LDO can provide 1.2V by post-regulating the 1.8V rail with greater than 66% efficiency. One additional low noise linear output can provide a third voltage such as 2.8V for an RF analog rail. Figure 5 shows the three digital multimedia broadcast module input power rails powered Micrel MIC2800 high efficiency switcher and low input voltage LDO combination and the corresponding average efficiencies for every rail. The Micrel IC also offers a LOWQ™ mode which reduces the total current drawn to less than 50uA. The MIC2800 is a uCap design, operating with very small ceramic output capacitors for stability reducing solution footprint and cost. The DC-to-DC converter provides virtually no noise in light load mode and just 75uV_{RMS} output noise in LOWQ™ mode. This allows designers to avoid higher noise light load modes that have traditionally interfered with sensitive RF circuitry. The part also integrates a POR circuit that allows monitoring all three output voltages. Independent enables for the switching and two linear regulators provide maximum design flexibility. Compared to the smallest discrete solution currently on the market consisting of one switching DC-to-DC and two LDOs, Micrel's MIC2800 solution footprint is 25 percent smaller.

Tackling the inductor

At the end of the day reducing the size of the

inductor and output capacitor is the key to higher acceptance of high efficiency by switching regulator solutions into mobile phones. The most promising approach that researchers have been deploying is to shrink the inductor size is by switching at faster frequencies. Not too long ago, switching regulators all operated with frequencies of several hundred kHz. The inductor size of a switching regulator is inversely proportional to its operating frequency. Buck regulators, operating at 500 kHz, commonly use inductors in the range of 10uH. In comparison, switching regulators, operating at 1 MHz, just need 4.7uH of inductance. Assuming everything else is equal, this solution reduces the volume of the required inductor by 50 percent. A low profile 4.7uH inductor that is capable of continuously delivering 500 mA, typically comes in a footprint of around 16 square mm and a profile height of around 2mm.

Responding to the demand for smaller inductors in space-sensitive applications, leading analog IC suppliers have

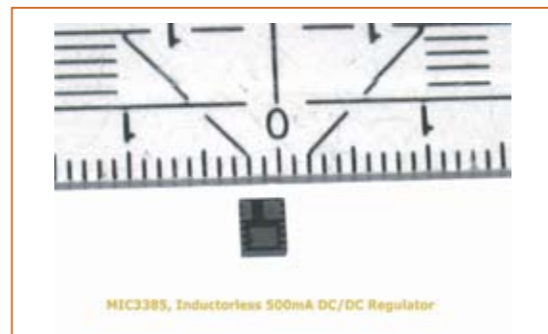

Figure 7: Micrel MIC3385, Inductorless 500mA High Efficiency Buck Regulator, In A 3mm x 3.5mm x 1mm MLF® Package.

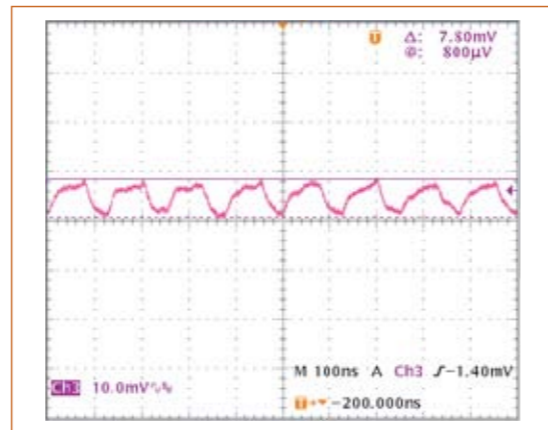

Figure 8. Less than 8mV output ripple achieved with inductorless MIC3385 buck switcher.

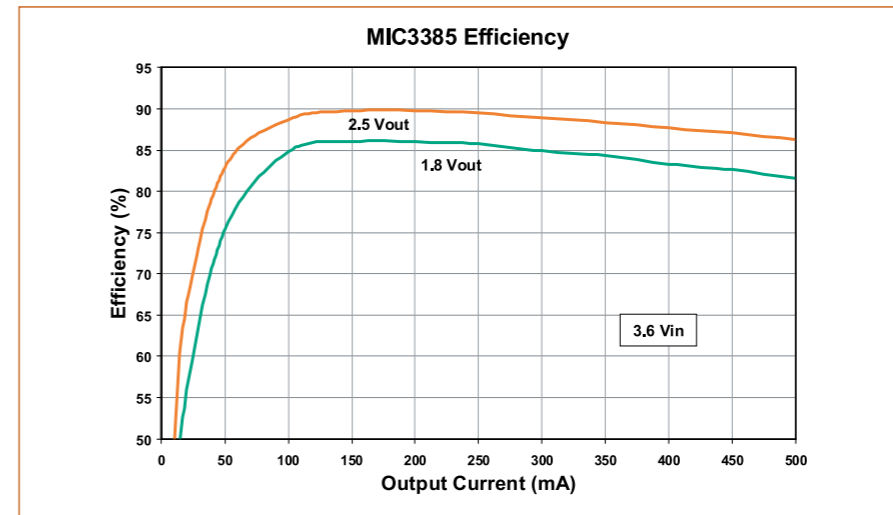

Figure 9: Micrel's MIC3385 Efficiency For 3.6V-to-1.8V and 3.6V-to-2.5V Conversions over Load Current.

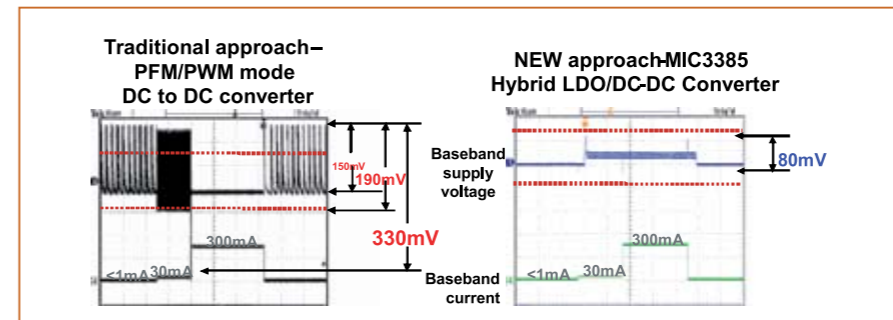

Figure 10: Comparison of Load Profiles For An Industry Standard Buck Regulator Using A PFM Light Load Scheme Compared To The New Inductorless MIC3385 Offering A LDO Light Load Mode Exhibiting A Stable Output Voltage As Load Profile Changes.

engaged in a speed race over the past few years, coming out with switching regulators featuring faster and faster frequencies. TI announced a 3MHz device in 2004. This was followed by Linear Technology and Maxim announcing 4MHz capable devices last year. At 3-4MHz, the inductor value can shrink down to 1uH thereby reducing the inductor size to around 3x3x1.2mm.

In 2006, Micrel broke the 8MHz barrier by offering the industry's first 8MHz buck regulator. This solution features a tiny 0.47uH chip inductor that measures a mere 1.25mm x 2mm x 0.55 mm; another 95 percent reduction in inductor volume compared to a 1MHz solution (refer to Figure 6). As shown in the illustration, this is also the first time the inductor actually became smaller than the switching regulator IC package itself. Now, the inductor has shrunk 40 times in volume compared to a 500 kHz

converter.

Eliminating the inductor completely, Micrel has recently started sampling an inductorless high efficiency buck switching regulator. The device, the MIC3385, is rated for up to 500 mA and comes in a tiny 3mm x 3.5mm x 0.9mm MLF® package (Figure 7). In spite of the missing inductor the ripple performance is below 8mV and efficiency is respectable with up to 90 percent. Figure 8 shows the ripple performance and Figure 9 shows the efficiency curve over load current for a 3.6-to-1.8V and 3.6-to-2.5V conversion. Note that a linear regulator would feature just 50 and 69 percent conversion efficiency in these cases. The Micrel device features a light load mode with only 20uA of ground current. Also, output noise and transient performance are excellent thanks to a fixed-mode frequency operation supported with a light load LDO that assists the switcher dur-

ing demanding load transients. Figure 10 shows the MIC3385 noise and transient performance in comparison to an industry standard buck regulator with a PFM light load scheme. As can be seen at loads of <1mA, the industry standard part produces up to 150mV noise on the output while the noise on the MIC3385 is virtually not measurable. At loads of about 30mA, the part with the PFM mode generates a different band of noise with about 190mV of peak-to-peak deviation while the MIC3385 is still quiet. The load transition from PFM-to-PWM mode finally is where the largest deviation in output voltage is seen on the industry standard part. In the new MIC3385, the LDO mode supports the switcher in this transition and the overall output voltage droop is held under control. This allows for excellent overall transient and noise performance using small output capacitors thereby further integrating the solution. The industry standard part would need five times the output capacitance to achieve the same performance.

Conclusion

Ever increasing functionality in mobile phones, longer battery lives as well as compact and lighter weight designs are presenting immense challenges on cell phone designers. The cell phone makers that manage to overcome these challenges the best can differentiate themselves in a crowded market place and ultimately thrive by reaping the rewards of a huge market that approaches one billion handsets.

Fierce competition and advances by semiconductor suppliers hold the key to overcoming the challenges cell phone makers are facing. Digital chips are continuing to shrink through integration and the usage of smaller process geometries. Analog power management advances are being made through innovative packaging and creative designs that shrink the overall solution size and external component sizes. Micrel has demonstrated advancements in popular LDOs using new miniature packages and is setting new standards by pushing the frequency barrier in switching regulators to 8MHz and even providing an inductorless high efficiency switching regulator.

Intelligent Power Supply Design

Digital control becomes viable

Digital intelligence in analog power supply design is proving to be a benefit to an increasing number of designs providing extra features with little resource spent in time and cost.

By Lucio Di Jasio, Application Segments Manager, Microchip Technology Inc

Switch-Mode Power Supplies (SMPSs) are traditionally implemented using a basic analog control loop. Recently, advances in digital signal controllers (DSCs) have enabled designs where fully digital control schemes begin to become practical and economical. Still, early adopters of this digital technology are expected to be at the high-end of the applications spectrum, where the benefits of full digital control are the most immediate. However, there are a large number of applications that can greatly benefit from the configurability and intelligence provided by augmenting basic analog designs with even the smallest and most inexpensive microcontrollers.

There are, in fact, at least four discrete stages of digital control adoption in power-supply systems:

1. On/Off Control
2. Proportional Control
3. Configuration Control
4. Digital Feedback, or Full Digital Control

This article focuses on the first of these stages – on/off control. Looking at this stage, some compelling applications are possible.

For example, by simply toggling the shutdown input (used to disable the MOSFET driver outputs) of a more traditional switching power supply, pulse-width-modulation (PWM) techniques

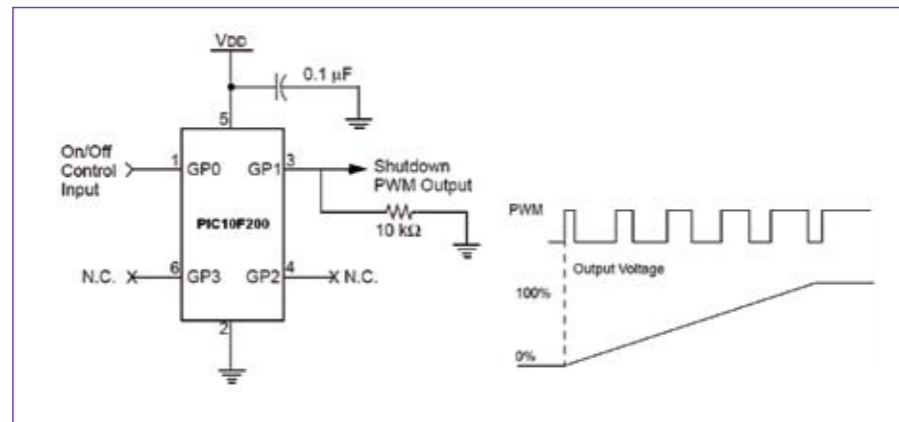

Figure 1. Example of Soft-Start Control Using a PIC10F200 Microcontroller.

can be applied to control the amount of time the power supply is allowed to operate, slowly increasing its operation from 0% to 100% (see Figure 1). This immediately provides a flexible “soft-start” that can help prevent the large

inrush of currents typically associated with the startup of a switching power supply.

Even the smallest microcontroller has at least four I/Os available and

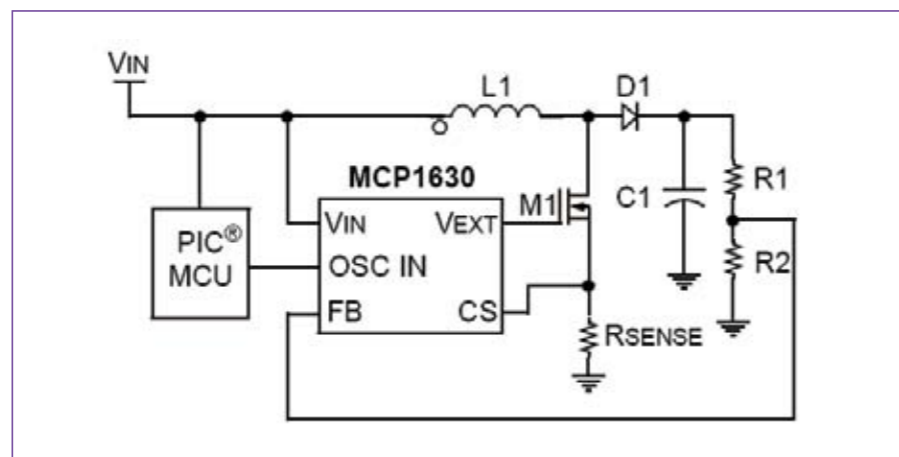

Figure 2. Using a PIC® Microcontroller as a Clock Source for a Booster Circuit.

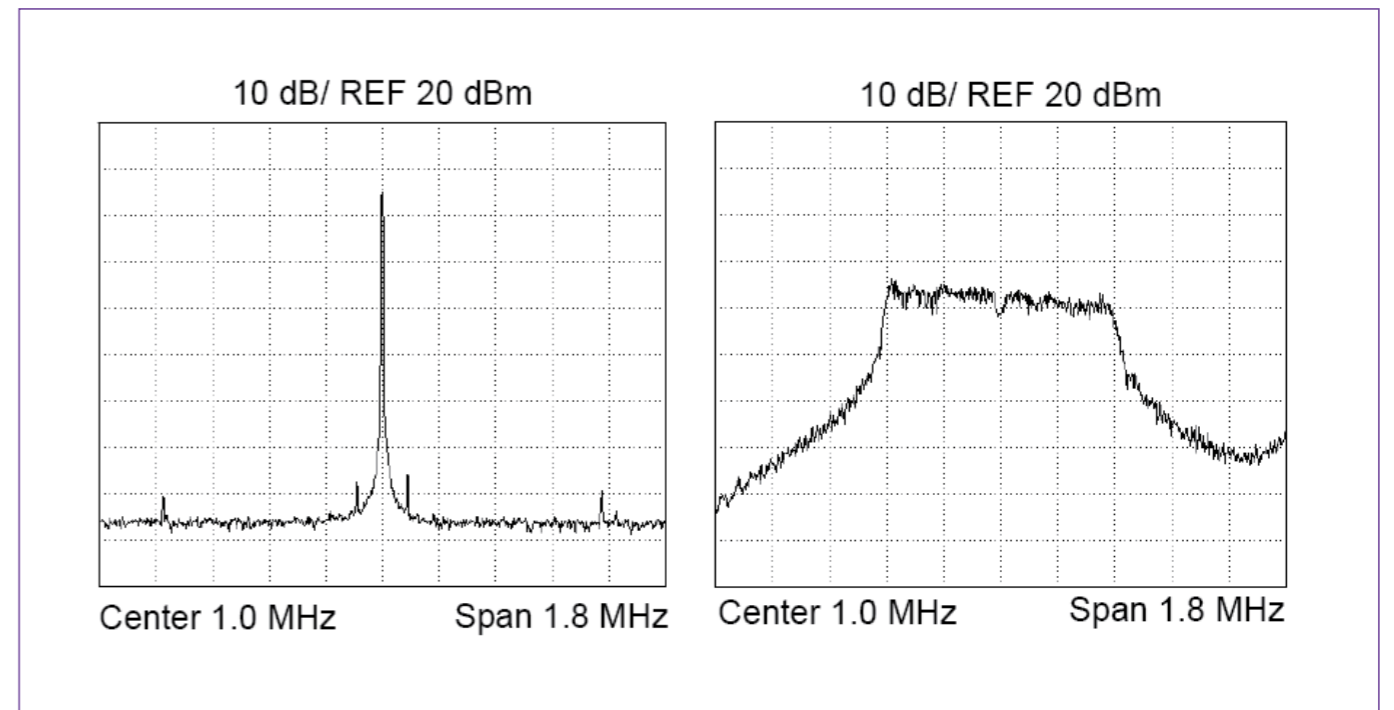

Figure 3. Spectrum of the Clock Output Before and After Dithering.

a level of computational power that greatly exceeds the requirements of this application, so this concept can be immediately extended to two or more outputs. This enables simultaneous control of multiple switching regulators, which sequences the outputs into a precise order. Additionally, if the microcontroller used offers an on-board comparator and a voltage reference, it can be used to implement an effective under-voltage lockout, or to perform tracking to ensure that two outputs ramp up at the same rate.

Another example of a relatively simple way to add intelligence to power supplies involves using the microcontroller’s (4 MHz) internal oscillator. This oscillator can be used as a clock source for a switching-regulator PWM generator circuit, as shown in Figure 2.

In this example, the clock signal is connected directly from the microcontroller’s clock output pin (typically divided by 4, resulting in a 1 MHz reference). Alternatively, if available, a PWM peripheral onboard the microcontroller can serve as a source for the switching-regulator PWM, providing better control over the duty cycle and frequency.

Microcontrollers’ internal oscillators are typically temperature-compensated RC circuits, and they are generally provided with an initial default factory calibration. However, with the microcontroller’s oscillator calibration registers (OSCALs), the user can adjust the oscillator frequency-on the fly-through software. This feature can be advantageous in helping to meet emissions requirements, as mandated by the Federal Communications Commission and other regulatory organizations. In fact, when switching at a fixed frequency, typical SMPS circuits produce sharp peaks of energy.

Using a simple pseudo-random sequence to vary the OSCCAL setting, the power supply can sweep a range of frequencies from approximately 600 kHz to 1.2 MHz. The random number generator is easily implemented in a few lines of code by utilizing a Linear Feedback Shift Register, a well-known technique that requires minimal coding effort with 8-bit microcontrollers. By detuning the internal oscillator, a power supply’s energy can be spread out over a wider range, so that the magnitude of the emitted energy at each individual frequency is reduced by as much as 20 dB, as shown in figure 3.

In summary, there are many simple ways in which power supplies can be sprinkled with a little digital intelligence to improve their performance. In these ways, power-supply designers can get a lot of mileage with very little time and money.

www.microchip.com



Got Power?
We have!

www.power-systemsdesign.com

Lighting Systems Part I



Power Electronics in Public Lighting Systems

Are LEDs the only viable solution?

Legislation concerning efficiency and the power factor of loads connected to the power line is becoming more and more rigid. The cost of energy is high and is increasing. Not less important are the environmental considerations of wasted energy turning into harmful pollution.

By Giampaolo Pantaleoni, R&D engineer, Bentivoglio (BO), Italy

Currently public lighting systems are realized through various points of light distributed over a public area to be lit. These points of light generally use high intensity discharge (HID) lamps and in particular, the high-pressure sodium types. This last kind of lamp has particular characteristics that make it suitable for the application. The luminous efficiency is quite high and the spectral luminous distribution, even if mainly concentrated on yellow, has a certain content of the other colours of the visible spectrum. Other types of lamps (e.g. low-pressure sodium) have greater efficiency, but the luminous emission is concentrated on a single spectral line, preventing therefore the recognition of colours, with obvious security problems for nocturnal driving. Considering the extremely fast progress

in LED technology, it is not difficult to imagine that in the near future, LED-based lighting systems will be in competition with current technology. LED devices have also the certain advantage of having the highest average life and absence of ageing. These characteristics are of primary importance in the public lighting field.

Coming back to current times, it must be noticed that discharge lamps cannot be connected directly to the supply line (figure 1). To ignite them it is necessary to provide an extra voltage of some kV. Once the arc has fired, in order to limit the current, a choke in series with the lamp is typically used. In these conditions, the current absorbed from the main line is out of phase with the voltage (current is

delayed compared with the voltage) and shows a considerable amount of distortion. In order to obtain an acceptable power factor (PF), a re-phasing capacitor is commonly used.

It is exactly at this point that electronics enters the game. All these devices, conveniently called control gear, can be replaced with an electronic device able to offer several advantages. Obviously, these are still more important if in addition to modern power devices available on the market, you use a microcontroller to implement an intelligent control strategy. The continuous decrease in the cost of electronic components and the regulatory pressures now applied make the electronic solution more and more competitive.

As regards legislation issues, three main arguments can be summarized:

- 1) quality of the lighting service
- 2) electrical requirements
- 3) energy saving

For the first point, a light source suitable for the traffic on the road and with a sufficiently homogenous distribution must be guaranteed. Moreover, the number of faulty lamps must be less than a predefined limit. For the second point, legislation concerning the power factor of loads connected to the power line is becoming more and more restric-

tive. Thirdly, for energy saving, it must be kept in mind that the cost of energy is high and is continuously increasing. No less important are environmental considerations. Wastage of energy, in fact can turn into useless and harmful pollution. Recent European norms impose the use of chokes with an efficiency level over a certain minimum. The power lost in heat in these components could reach 10% of the power supplied to the lamp. Considering that the lamp remains on approximately 4000 hours/year, it translates that for a small 100 W lamp, every efficiency increment of a percentage point, means 4 kWh saved every year. This figure multiplied by the number of lights active in the world, leads to huge proportions.

The systems currently in use for energy saving in public lighting, can be synthesized into three main groups:

- 1) At a certain time of the night, alternate lamps are switched off. Naturally, this solution (probably the most diffused), does not concur to obtain a uniform lighting and it is unlikely that it will be applied to roads carrying a significant amount of traffic.
- 2) The supply voltage is lowered during the night, starting from a given hour. This solution will hardly adapt to lines in which lamps of different technology are used. If a lamp works at 50% of the nominal power with the given voltage, lamps of a different technology can work for example at 30% or 70% of their nominal power.
- 3) A device installed on every point of light, at a defined hour of the night reduces power for example up to 50% of the nominal.

In all the three cases the lamps are powered through the traditional electro-mechanical choke. A totally electronic solution, however, offers numerous advantages in many areas. The more usual topology makes use of a booster type input stage and a half bridge output stage. The booster allows the execution of the PFC (Power Factor Correction) function, closing the Power Factor (PF) to one. With a design goal to use small and inexpensive chokes with low losses, it will be necessary to operate at frequencies around one hundred kHz. The power devices that

best fit the application are MOSFETs. Powering the lamp with high frequency currents, leads to another important advantage. The lamp works with a more constant ionization level and consequently generates greater luminous emission at the same power consumption. Measures carried out on Compact Fluorescent Lamps (CFL) bring back an increment of luminous emission of 20% (ST, AN1546). Of course, things will not be so good for every type of lamp. As regards the efficiency of the electronic circuit, today's generation of power MOSFETs provides excellent performance. As an example, in a prototype for firing 100 W lamps, the increment of temperature measured on the case (TO220 in free air) of the 2 MOSFETs in the final stage, was of approximately 25 °C. This means that the total power dissipated into the final stage is 800 mW only. Moreover, the MOSFET in the PFC stage shows improved performances in terms of power dissipation. Of course, in the complete equipment there will be other power losses distributed over various parts of the circuit. However, a careful design for every part of the

circuit (in particular, magnetic components), promises high overall efficiency.

Additionally, intelligent control of the power supplied to the lamp, can contribute to power savings up to a figure of 25-30%. In the nocturnal hours, during which road traffic is significantly reduced, luminous emission can be lowered. One simple reduction after a fixed time period is inadequate. In fact, between summer and winter, the timetable for ignition of the public lighting systems can vary up to 5-6 hours. A reduction after a fixed time will bring this decrease in light too late in winter or too soon in summer. With a small microcontroller (in the prototype a PIC16F870 from Microchip) it is possible to implement algorithms that modulate the intensity of the light, adapting it to the period of the year and the time of the night. Those changes in light are carried out completely automatically (without use of sensors or extra communication lines). A typical summer situation is showed in figure 2 (red line). Lamps are fired at nominal power at 21:00. At 23:00 the power is gradually reduced in order to

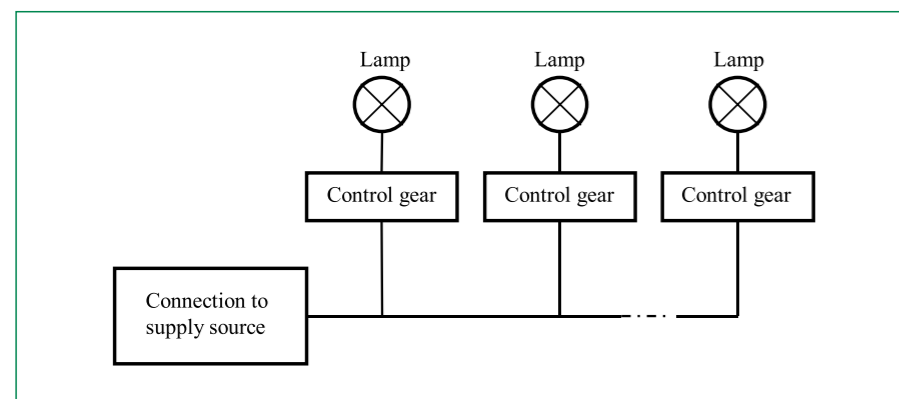

Figure 1: Lamps need high voltage in control gear to ignite.

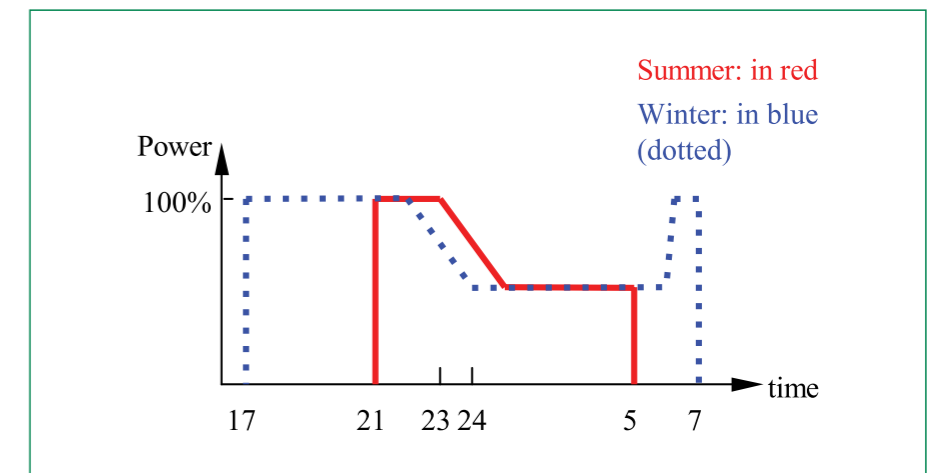

Figure 2: Timing and power levels for summer and winter.

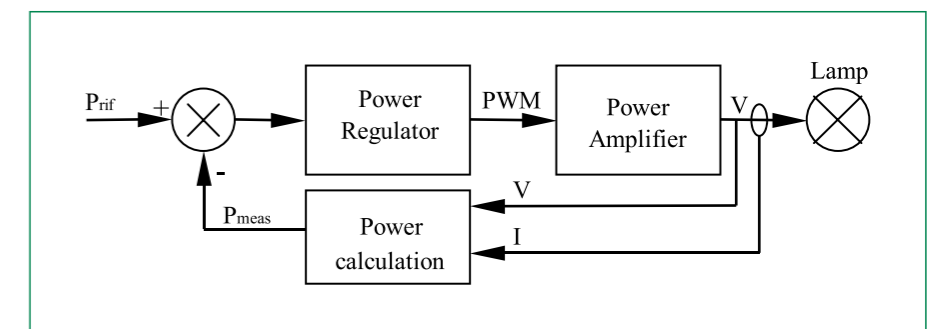

Figure 3: Power loop regulation.

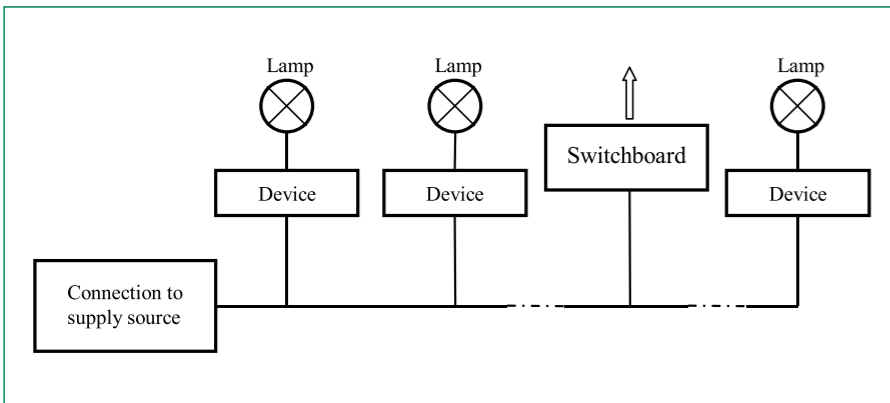

Figure 4: Low Cost diagnostic function.

adapt to the diminishing traffic. From 01:00 on, power is held at the minimal value. The light is finally switched off at 05:00. In the same figure, also shown is an example relative to the winter season (blue line). Lamps are fired at 17:00 and maintained at the nominal power until 22:00. After this time, light is gradually reduced until at minimal power. This happens around midnight. When traffic begins to increase, about 06:00, power is ramped again to the maximum value. In the example, daylight saving time is used. This idea is protected by a pending patent.

The use of a microcontroller enables a simple, full digital power regulation. Figure 3 illustrates a block diagram of the power loop. The measured power is compared to the reference and PWM (Pulse Width Modulation) is adjusted consequently. Therefore, the output power follows the desired reference. In a wired prototype, a small 8-bit microcontroller with 10 MHz clock closes the power loop every 800 μs. This time is short enough for the application. A true power regulation opens the door to two important advantages. The first is about the duration of the lamps, while the second refers to the variation of the luminous emission with the aging of the lamp. As far as the first point is concerned, it is necessary to notice that manufacturers declare data about the average life of the lamp in conditions of stable and nominal supply. If the voltage frequently presents sudden changes, the average life diminishes drastically. A precise regulation of the power reduces significantly the voltage variations applied to the lamp which implies an increase in the average life. As for the second point, it must

be considered that the lamp supplied by the choke, with aging, reduces the absorbed power (the impedance increments) and luminous emission. The power regulation, maintaining constant the supplied power to the lamp, minimizes the light reduction. It is clear that this fact results in lower costs for the maintenance of the system and in a greater quality of the service.

A further advantage that an electronic solution offers is the ability to realize diagnostic functions at a particularly low cost. Figure 4 shows an example of this diagnostic concept. The power line supplies electric energy to the connected points of light. Every point of light uses this power line in order to transmit information about its operational state.

By means of a diagnostic system, you can concentrate the information concerning the whole lighting system at a single point (the switchboard in figure 4). The information collected at that point can be transferred in a simple way to another remote location. The plant manager, can then carry out interventions for maintenance only when they are required. In this way, periodic maintenance and costs are considerably reduced while service quality is improved. In the simpler and more economic form, the information collected will define whether the system is operating properly or if technical intervention is required. With reference to figure 4, two devices can be seen. The first makes the electrical measurements concerning the point of light to be monitored, processes them and finally takes care to send the required signalling across the supply line. The second one (switchboard), collects the

information coming from the whole plant and makes them available to the user. Embedding the diagnostic function into the electronic dimmer/ballast device, involves a dramatic cost reduction. In order to implement this function in the simplest form, cost of additional electronic components can be as low as 1€. Of course, for information transmission, no additional communication lines, radio systems or conveyed waves are necessary. Laboratory tests on a prototype show encouraging results.

Before concluding, there are some points that cannot be neglected. The electronic devices for public lighting system work in rather onerous environmental conditions. In winter, ambient temperature can go down below -20 °C, while in summer, if the device is assembled near the lamp, temperature can rise above +60 °C. In the design phase, a careful choice of all the components must guarantee a very high average life. A lamp, in fact, can reach 24000 hours of work.

As stated earlier, future public lighting systems will probably make use of LED technology. For cost and efficiency reasons these devices are not yet competitive with HID lamps. The use of power electronics and of a microcontroller-based supervisor appears to be viable. In particular, it could just be that intelligent control strategies, such as the reduction in lighting power during the hours of lower traffic volumes, will anticipate the entry of LEDs into the market of public lighting systems.

Pantaleoni.gp@libero.it

Compact and Flexible Off-Line SMPS Solution for LED Drive

Runs 10 lighting LEDs at an efficiency of nearly 85 %

LED's will make significant penetration into an ever wider range of lighting applications. The promise of greater efficiency, reliability and design flexibility are compelling factors for their adoption. Rapid improvements in brightness, efficiency and cost per lumen now seem set to greatly accelerate this.

By Rainer Kling, Applications Engineer, Power Management and Supply, Infineon Technologies AG
David Compton, Product Marketing Manager, Power Management and Supply, Infineon Technologies AG

This article describes an off-line switch mode power supply (SMPS) for LED drive in wide line input voltage applications from VACIN = 90 V up to 270 V. The application is fully protected against open loop gain (OLP), short circuit (OCP), over temperature (OTP), over voltage at the Vcc stage (OVP), and under voltage (UVLO). It also provides highly accurate power limiting in case

of over load (using Infineon patented Propagation Delay Compensation™). All protection features employ an auto restart mode. The LEDs are protected against high peak currents during load transients. The driver application uses the Infineon jitter system IC CoolSET™ F3 (with integrated CoolMOS™ MOSFET) and the TLE4305G as a constant voltage and current regulator. The ap-

plication is designed to drive 10 LEDs (350 mA) at an ambient temperature up to 125 °C with high efficiency and low standby power.

Circuit Description

The system comprises a low cost off-line discontinuous current mode (DCM) SMPS in forward mode using an ICE3B0365JG - the smallest system IC from the CoolSET™-F3 family. The circuit diagram (Figure 1) details a 24V, 10 W power supply that operates from an AC line input voltage range of 90 VAC to 265 VAC, and is suitable for open frame or enclosed designs.

The application is able to run with 10 LEDs at an efficiency of nearly 85 %. Figure 2 shows the efficiency (y-axis) versus output power (x-axis) of the LED SMPS at low line input voltage VACIN = 85V and high line input voltage VACIN = 270V for different numbers of LEDs. The TLE4305G provides constant current regulation. Figure 3 shows the regulation characteristic of the output stage. The output voltage (x-axis) rises with increasing load from POUT = 0W (no LEDs present) until maximum load (10 LEDs). If maximum load is exceeded

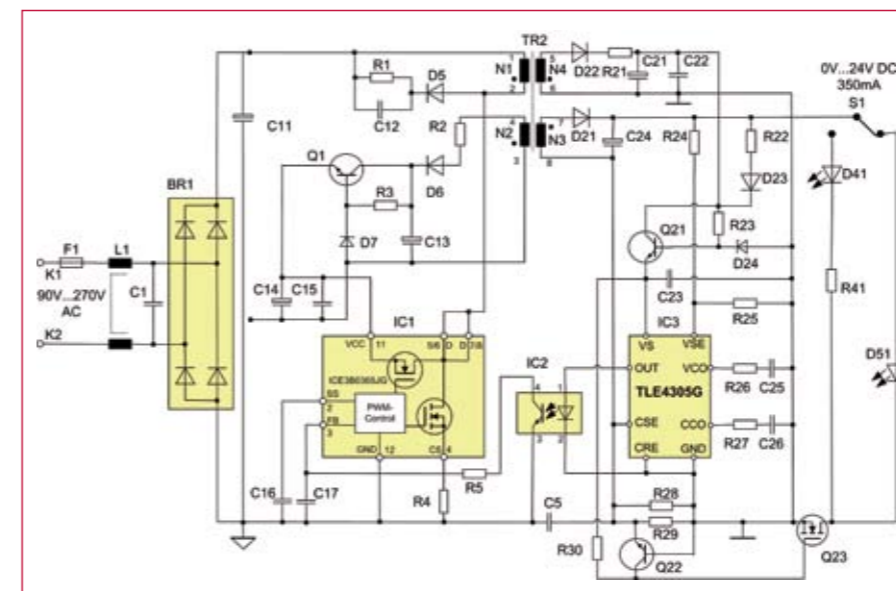

Figure 1: Schematic LED Application.

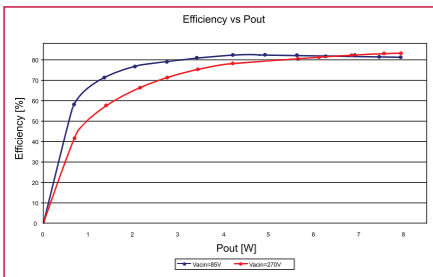

Figure 2: The efficiency (y-axis) versus output power (x-axis) of the LED SMPS at low line input voltage VACIN = 85 V and high line input voltage VACIN = 270 V for different numbers of LEDs.

the TLE4305G decreases the current (y-axis) down to zero and holds the output voltage stable at the maximum level of VOUT = 24V.

Upon application of the AC line input voltage, the integrated start up circuit charges the chip supply stage up to VCC = 15V and the controller starts working. To increase efficiency the start up circuit is then made inactive during normal operation. The IC will be supplied from the auxiliary winding N2 in forward mode via R2 and the rectifier diode D6. C13 and C14 stabilise VCC voltage through the range of operation modes. Due to the wide output voltage range from 0V up to 24 VDC, the chip supply voltage (VCC) of the CoolSET™ follows the line input voltage. In the case of VCC exceeding 19V, the network Q1, R3 and D7 clamps the chip supply voltage at VDC = 19V in order to protect the chip supply stage of the CoolSET™. An RCD snubber (R1, C12 and D5) clamps the drain source voltage below 600 V in order to prevent an avalanche breakdown of the MOSFET. Capacitor C16 provides soft start, reducing stress on the MOSFET / diode and preventing audible noise during start up. An optional low

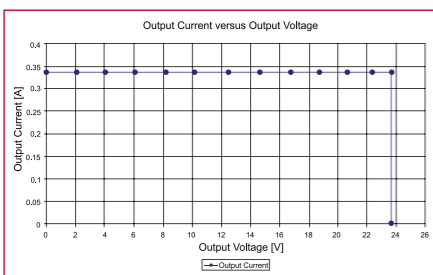

Figure 3: Controlled Output Current versus Output Voltage.

pass filter (C17 and R5) can be used to smooth the signal from the optocoupler (IC2) at the feedback PIN 3 of the CoolSET™. R4 adjusts the primary current.

The secondary side voltage is rectified via fast rectifier diode D21 with a low forward voltage. Capacitor C24 buffers energy for the output stage. The output voltage is set by divider R24/R25 to VOUT = 24 VDCmax. The chip supply voltage of the TLE4305G is rectified via diode D22. R21 (optional) and capacitor C21 perform energy buffering for the chip supply stage at PIN VS. C22 and C23 eliminate glitches on the chip supply stage. R22 and D23 ensure stable operation during no load condition. Due to the wide output voltage range from 0 V up to 24 VDC, the chip supply voltage (VS) of the TLE4305G follows the line input voltage. If VCC exceeds 12V, the network Q21, R23 and D24 clamps the chip supply voltage at VDC = 12V. R26, C25 and R27, C26 are compensation networks for the output voltage and current. The current is sensed via shunt resistors R28 and R29. In the case of load transients, a current peak occurs. This current peak could result in damage to the LEDs. If the application inherently generates transients (e.g. when switching between LEDs of different colours), an optional compensation network can be implemented. The network R30, Q22 and Q23 control such peak currents and limit the discharging current from the capacitor C24.

CoolSET™ System IC

CoolSET™ F3 is a current mode control PWM IC with an integrated CoolMOS™ Power MOSFET in one package. It enables a low external component count SMPS; standard applications require only 7 external components. CoolSET™ combines the superior technology of a high voltage CoolMOSä and the optimized technology of the control IC. It offers enhanced protection features - all with auto restart - and a smart standby power concept using active burst mode. The integrated start up circuit obviates start up resistors. This cuts cost and allows high speed start up and increased efficiency. A programmable blanking window allows a short term current overshoot which prevents switch off in the event of a brief over current transient. The integrated Propagation

Delay Compensation™ is responsible for highly accurate power limiting across the whole line input voltage range. This feature reduces the electrical stress and enables a cost effective SMPS design. The integrated 650 V highly rugged CoolMOS™ eliminates or reduces the need for a heat sink and permits an SMPS design with a simple RCD snubber. Extremely low specific ON resistance reduces conduction losses and supports operation at high ambient temperatures. The integrated frequency jitter improves EMI performance and simplifies filter design.

TLE4305 Constant Voltage and Current Regulator

The TLE4305G is specifically designed to control the output voltage and current of an SMPS. Independent compensation networks for the voltage and the current loop can be realized by external circuitry. The device contains a high accuracy bandgap reference voltage, two operational transconductance amplifiers (OTA), an optocoupler driver output stage and a high-voltage bias circuit. The device is based on Infineon's double isolated power line technology DOPL which enables high precision bipolar voltage regulators with breakdown voltages up to 45V. Efficiency is further improved by the very low voltage drop (only 200mV) across the shunt resistors R28 and R29 of the TLE4305G.

Conclusion

This off-line LED SMPS solution-using the Infineon ICE3B0365JG CoolSET™ and TLE4305G IC's - was designed to give maximum safety, reliability and improved EMI performance whilst protecting the LEDs during load transients. The compact design is able to be used worldwide and has a high efficiency with differing numbers of LEDs. The circuit also features a highly accurate output current control and a very low standby power rating during no load condition. The high level of integration in both devices enables maximum of protection features with a minimum of external components - resulting in a cost effective SMPS design.

www.infineon.com

RGB LEDs Lead the Way for Flat Panel Displays

Broader spectrum and higher efficiency

LED backlighting is becoming increasingly popular versus CCFL (Cold cathode Fluorescent Light). LCD display panels with RGB LED backlighting render superior color reproduction that enhances the viewing experience.

By Bjoy Santos, Field Applications Engineer, Intersil, Milpitas CA USA

Unlike the typical CCFLs, RGB LEDs expand the range of visible colors. CCFL backlit displays have a limited color gamut (spectrum), and lack color vividness. See Figure 1. CCFL exhibit approximately 80% of the

NTSC (National Television System Committee) defined colors while RGB can reveal up to 110% of the NTSC color gamut enabling a more accurate representation of images on screen.

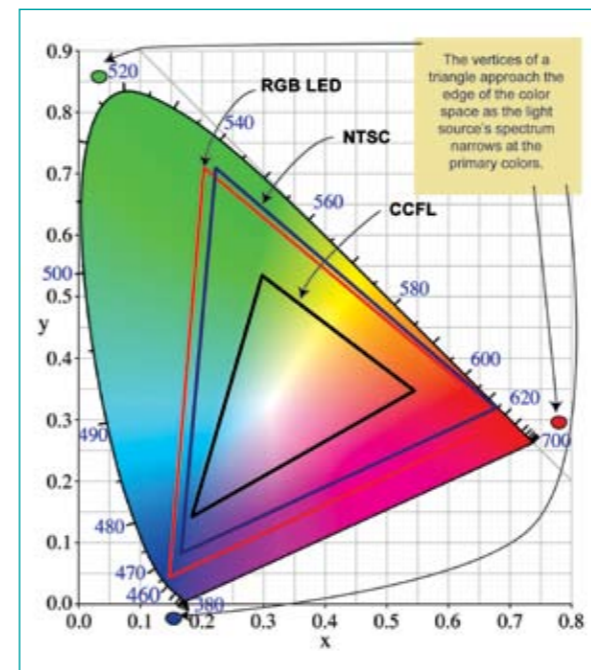

Figure 1 CIE color space resembles a horseshoe shape. (1)NTSC displays all colors within borderline of the CCFL triangle. (2)CCFL backlit display lacks vibrant colors. (3)RGB LEDs backlighting extends the NTSC color space.

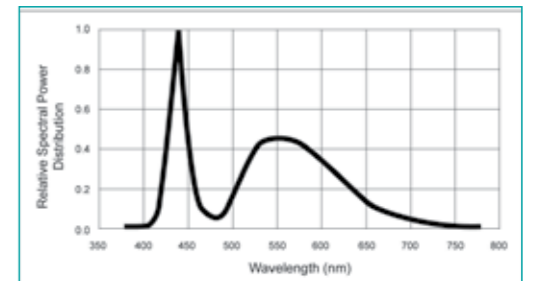

Figure 2 White LED typical spectrum. The broad spectrum of a white LED limits the color gamut of a display when used as a light source in the display panel.

The largest possible color gamut is achieved by using three monochromatic light sources such as blue, green, and red lasers. When viewed in the spectrum, lasers have narrow bands of energy at the 380nm, 520nm, and 700nm wavelength. The narrower the band, the closer it is to the edge of the CIE horseshoe, and hence the larger the region of the color gamut.

White LED vs. CCFL

White LED backlighting is well suited for handheld and mobile display panels because it is available in smaller form factors, is simpler to drive, is less sensitive to mechanical stress, and has twice the

life expectancy. In addition, the rapid advancement of white LEDs' emission efficiency has made them a favorable choice in backlighting larger display panels such as notebook panels, LCD monitors and TVs. White LEDs have achieved 100 lumens/watt—an efficiency twice that of widely-used fluorescent lamps.

However, white LEDs share the same disadvantage in color gamut because a white LED is equivalently a broad-band light source. A white LED is a blue diode covered with phosphor to convert a portion of the blue light to yellow light. The blue and yellow bands peak at 445nm and 540nm respectively. The combined spectrum is perceived as white light. See Figure 2. In order to achieve a larger color gamut, the light source has to

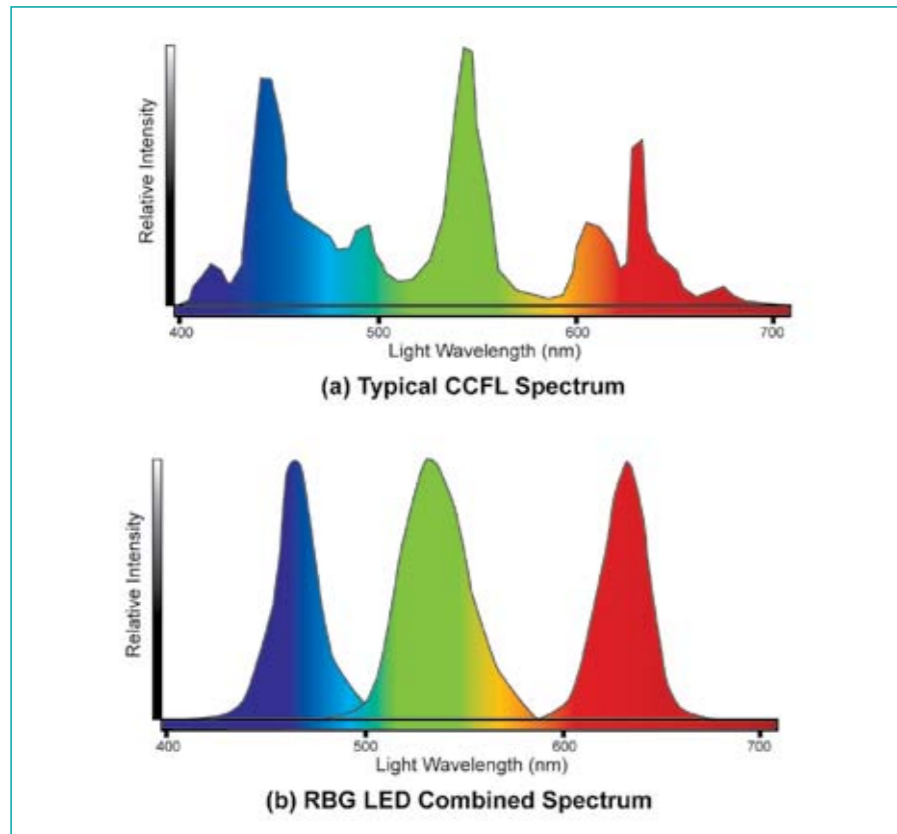

Figure 3. CCFL vs. RGB LED comparison. (a) Unwanted colors in the CCFL spectrum detracts LCD's color gamut display. (b) RGB LED has a narrow band at the primary colors.

consist of narrow bands at the primary colors.

Why RGB LEDs?

RGB LEDs come close in delivering narrow-band spectrum (Figure 3b) at a fraction of the cost compared to monochromatic light sources. CCFL, which is a broad-band light source, radiates a wide spectrum of colors shown in Figure 3a. Although both CCFL and the combined RGB spectrums are perceived as white by the human eye, the broad spectral range of the CCFL limit the color gamut of panel displays because of unwanted colors such as orange, yellow and cyan. Color gamut can also be improved by filtering the primary colors into a narrower spectrum. However, color filtering greatly attenuates the amount of light, reducing the overall brightness. Color filtering as of today is not a practical solution.

Not only does the RGB LED improve color gamut, it also improves efficiency as well because RGB LEDs only emit optical energy that is needed—red, green and blue. Broadband light

sources such as white LEDs and CCFL have a relatively high presence of unwanted colors which deteriorate the color gamut and therefore cause a loss in efficiency.

Because individual colors can be driven independently, the white point or the color temperature of an RGB LED can be corrected, while the CCFLs and white LEDs have a fixed white point.

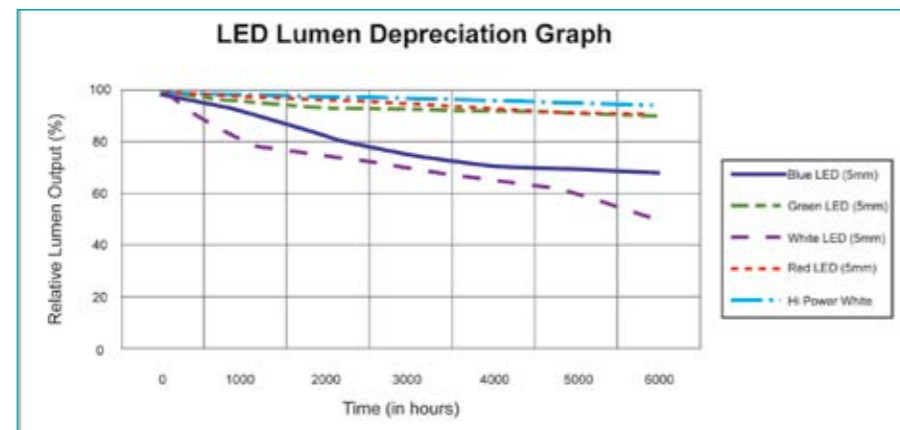

Figure 4. LED typical lumen output vs. time.

There are added complexities in driving RGB LEDs. First, there is an aging effect or lumen depreciation over time which is measured in change in lumen output versus time. Most light sources will dim when driven with a constant current. For a white LED and CCFL, light depreciation due to aging is easily compensated by driving them with more current. This is not the case for RGB LEDs. It is a little bit more complicated because each color has a different depreciation rate. See Figure 5. Red and green LEDs typically dim by 10%, while blue LEDs deteriorate to 70% after a year. For this reason, color temperature and luminance of an RGB LED are both degraded over time when driven with a constant current source. Light depreciation for each color has to be determined individually before compensating with higher current. Otherwise, the color temperature or white point will be altered. A method compensating for light depreciation is shown in Circuit 1.

The effect of temperature is another concern. For CCFL and white LEDs, light variation due to temperature deviation is compensated by driving more or less current through the light source. RGB LEDs add a bit more difficulty. Blue has a positive temperature coefficient while red and green, although both negative, also have different temperature coefficients. See Figure 6. A crude method is to have a temperature sensor monitor the light source and determine how much current to drive the individual colors. Compensation due to temperature fluctuations is also accomplished in Circuit 1.

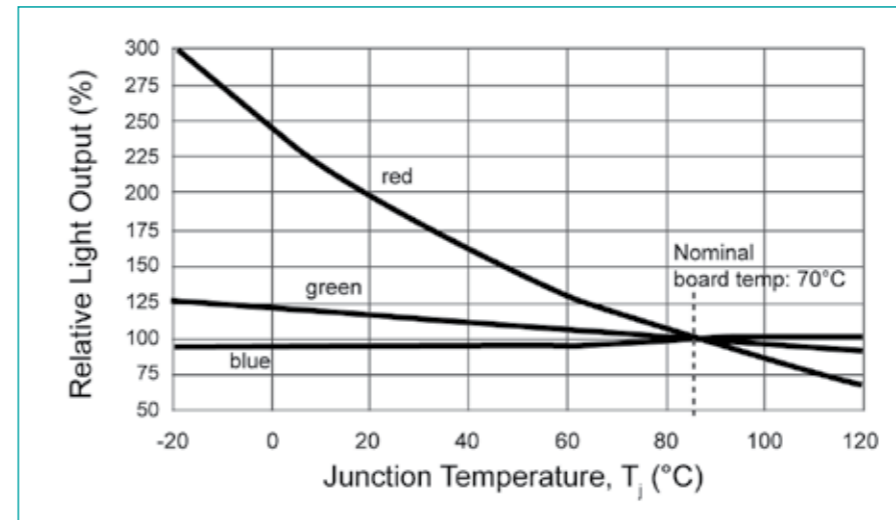
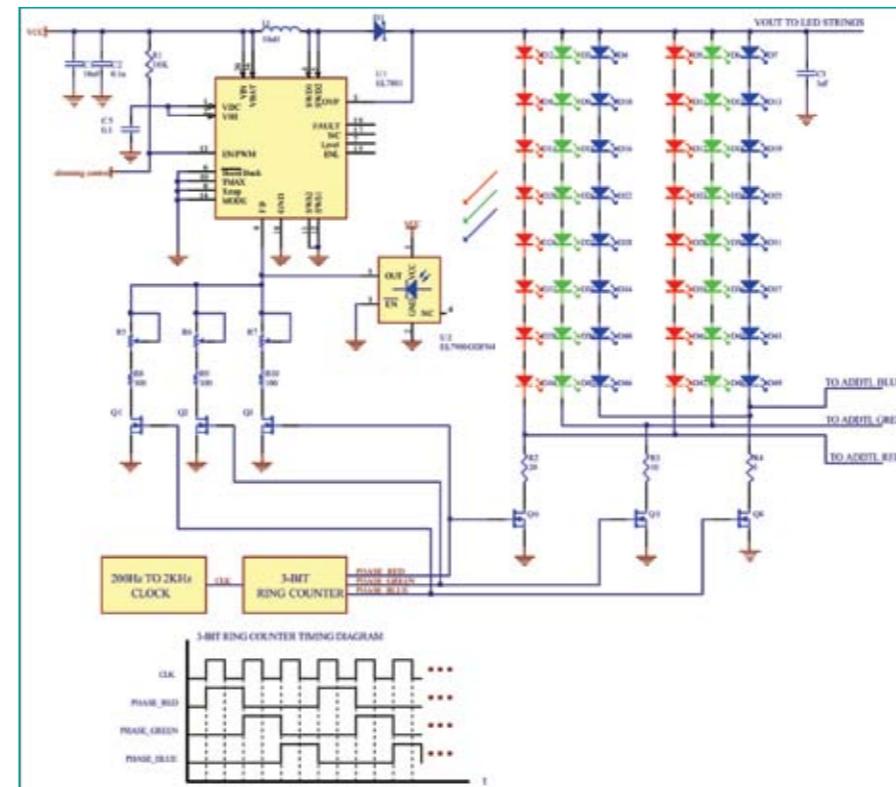

Figure 5. Relative Luminous Light Output vs. Junction Temperature for individual colors.



Circuit 1. RGB LED driver with optical feedback.

A method of driving strings of RGB LEDs with an optical feedback loop is shown in Circuit 1. An inductor-based boost converter, the EL7801, drives a combination of series and parallel RGB LEDs. The EL7900 is an optical photosensor that senses and converts optical signal into an electrical signal. The electrical signal is fed back to the EL7801 controller to adjust the current through the LEDs. A unique modula-

tion technique with the use of a 3-bit ring counter is employed such that a costly RGB optical sensor is avoided. The circuit ensures that the luminance (brightness) and the white point (color temperature) are kept constant over time and regardless of temperature fluctuations.

Each color is turned on sequentially one at a time at a rate determined by

the clock CLK. See 3-bit ring counter timing diagram in Circuit 1. During the first clock cycle, PHASE_RED is exclusively high; PHASE_GREEN and PHASE_BLUE are low. Consequently, transistor Q6 is on to conduct current through red LEDs, and transistor Q3 is on to allow current path from the EL7900 light sensor, whose current output IOUT is proportional to the optical output of the red LED. Note that only red light is present during PHASE_RED. Red intensity is adjusted via variable resistor R7 whose resistance is inversely proportional to red light intensity. The lower the resistance, the higher the red luminance because the EL7801 controller will boost the current through the red LED, increasing red intensity until the voltage at the FB is at its nominal value of 100mV.

On the second clock cycle, PHASE_GREEN is exclusively high, turning off Q3 and Q6 and shutting off the red LED. During this phase, Q2 and Q5 are on. The light sensor sees green light alone and starts another closed loop operation with the green LED.

The third cycle exclusively closes the loop on the blue LED. Note that the light sensor exclusively converts one color light at a time while the other colors are off. This method of modulation avoids the use of an RGB sensor.

At extremely slow clock rates, one can see individual colors turn on at a time. At higher clock rates we perceive a constant white light because the human eyes are natural integrators. The complete cycle is analogous to a color wheel composed of primary colors. When spun slowly, humans see red, green and blue separately. When spun fast, the human eyes integrate and the human perception is a white wheel.

Highly Integrated IC Enables LED Lamps to Meet EMC and Power Quality Standards

Plug-in replacements now become a reality

Incandescent lamps are being replaced by more efficient lighting technologies such as compact fluorescent and LED bulbs, but early attempts caused problems with EMC and current unbalance on the supply.

By Don Ashley, Product Marketing Manager, Power Integrations

Energy conservation in lighting applications is receiving increased attention as evidenced by changing regulatory standards in Europe and America. Incandescent lamps are being replaced by more efficient lighting technologies such as compact fluorescent and LED bulbs. The introduction of more efficient high brightness white LEDs (HB LED) in the past couple of years has made this approach especially attractive. The most meaningful metric when comparing lighting technologies is luminous efficiency, which specifies the amount of light generated in the visible spectrum in lumens per watt of power supplied to the lamp. Incandescent and halogen bulbs are particularly poor in this regard, with efficiency ratings in the 15 to 20 Lm/W range. Compact fluorescent lamps are much better, with a typical value of 50 Lm/W. However, within the past year, HB LEDs have surpassed even this figure and are expected to reach values of up to 150 Lm/W by 2012. In addition to its greater energy efficiency the LED lamp has other significant advantages, including longer operating lifetime and lower oper-

ating and maintenance costs. Because of these factors the HB LED lamp is expected to be a significant product for both residential and commercial usage for years to come.

The fastest and easiest way to take advantage of this new lighting technology is through the retrofit market - replacing existing incandescent and halogen bulbs with HB LED lamps. The goal is to integrate both the HB LEDs and their required drive electronics into a standard lamp housing such that it can be installed in an existing socket powered from the AC mains. The drive circuitry, or electronic ballast, provides the functions of line rectification, voltage reduction and generation of a regulated constant current to optimally power the LEDs. Needless to say, the physical space constraints within the confines of the lamp housing create some difficult design challenges.

Incandescent-replacement, retrofit LED lightbulbs have just recently started to be introduced, however they have suffered from several problems. Be-

cause it is tricky to fit the LED power driver circuitry into a standard bulb housing, some of these early LED light bulbs have no internal filtering, so they will not pass EMC standards. Moreover, many of them use an inefficient capacitor dropper power supply rather than a switched-mode regulated ballast. This approach can cause a current unbalance on the AC mains which can create power quality problems in some installations. Both compliance with EMC regulations and power quality are important issues and must be considered.

Recently, Power Integrations introduced its LinkSwitch TN family of power supply ICs in the tiny SO-8 package. This article describes a design for a high performance yet inexpensive electronic ballast for HB LED lamps using this chip that meets EN55022A EMI standards within the space limitations of standard lamp housings.

Design Objectives

This design is intended to power a string of three HB LEDs (the equivalent of a 12W standard incandescent light-

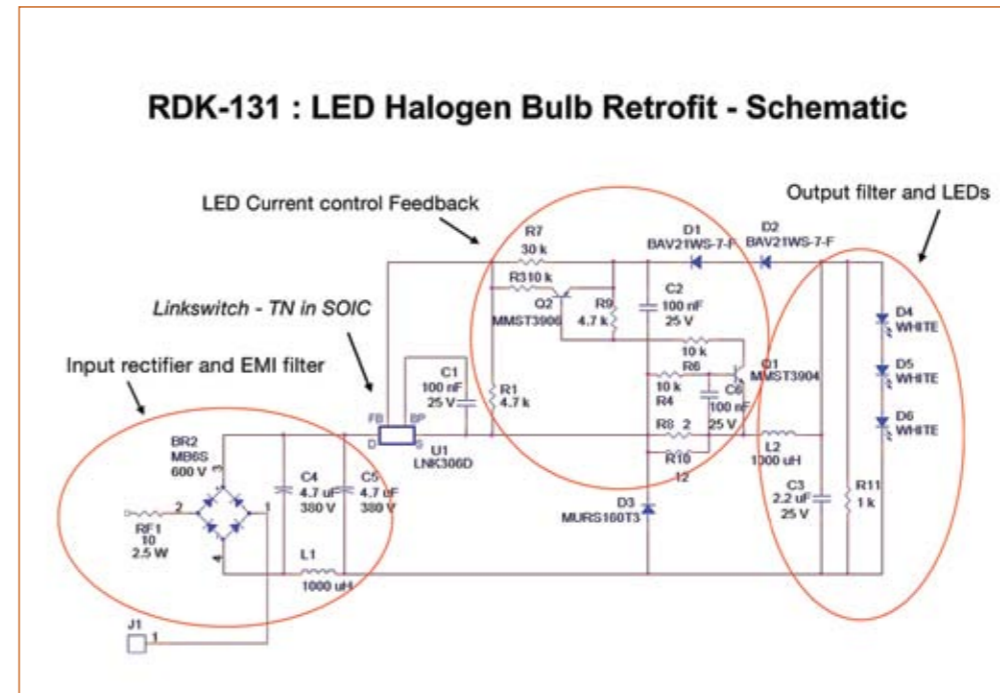

Figure 1. Schematic from RDR-131 Title "Converter and EMI Filter Schematic".

bulb) with a nominal current of 300mA. In normal operation, the output voltage is clamped at about 9.5 Vdc by the forward drop of the series LEDs, but this circuit has a compliance of up to 12 Vdc to allow for variations in diode performance. The topology is a switched-mode constant current offline buck regulator, and is capable of operation over the entire 85 to 265 Vac universal input range and at line frequencies from 47 to 64 Hz. Other objectives include high efficiency, low cost, and compliance to EN55022A EMI requirements. The design can be integrated into a standard lamp housing - either screw-in Edison or bayonet halogen configurations - to allow for convenient retrofit within existing lamps. The design (Reference Design Kit 131), is fully supported with design tools and applications assistance in order to minimize time-to-market for new HB LED lamp products.

EMI Considerations

Power Integrations has found that many LED light bulb designs on the market do not comply with conducted EMI specifications, due to both space and cost constraints. However, the design in this article takes advantage of the frequency jitter feature integrated into PI's LinkSwitch-TN power conversion IC, which means that a smaller EMI filter can be used.

Design Details

Power Integrations' LinkSwitch®-TN LNK306DN integrated power conversion IC includes a fully integrated 700 V power MOSFET so that no external power device is required. The offline non-isolated buck topology operates at a maximum frequency of 66 KHz in continuous conduction mode. This frequency is modulated with a 4 kHz peak to peak frequency jitter to simplify the design requirements for the EMI filter. Although in this design a buck topology is used, this IC is also configurable as a buck-boost converter. Crucially, the LinkSwitch®-TN LNK306DN is in the compact SO-8 package - a major benefit to the mechanical design for this application.

The schematic for both converter and

EMI filter is shown in Figure 1. The current control loop is set to the desired constant current value based on the voltage drop across the current sensing resistors R8 and R10. While the nominal design is for a current of 300 mA, it can easily accommodate output currents of up to 360 mA. Q1 and Q2 amplify the sensed voltage drop such that a lower resistance current sensing resistor can be used for purposes of minimizing power dissipation. The EMI filter utilizes a pi topology and includes a fusible flameproof resistor, RF1, for overload protection.

Only 25 components are required for the design for both converter and EMI filter, exclusive of PCBs and interconnects. A complete parts list for the design can be found in the referenced material.

The electrical design for this application is fairly conventional for this proven power conversion IC. The biggest challenge was the mechanical design, specifically integrating both the converter and the EMI filter into standard lamp housings. However, this design fits comfortably into either a screw-in Edison base (E27) or the bayonet halogen socket (GU 10). (Dimensions for the halogen bayonet socket are shown in Figure 2.)

Early on in the design process it became clear that a circular PCB large enough to house all the components

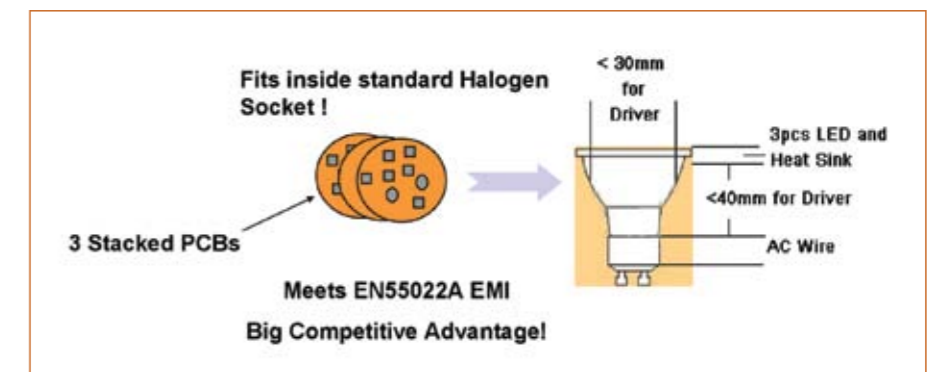

Figure 2. Drawing showing PCB and Halogen lamp base dimensioned side view Title "Mechanical Packaging Challenge".

for both the converter and the EMI filter would not fit into the lamp socket base. So a decision was made to partition the design onto two circular PCBs, one for the converter circuitry and another for the EMI filter. The final diameter of the converter board is 19.66 mm while the diameter of the EMI filter board is 16.91 mm. These boards were then stacked and interconnected with discrete wires to complete the assembly.

Although this design was functional, there was still a problem with conducted emissions. Because of the proximity of the two PCBs, there was coupling of switching currents from the converter board into the EMI filter board, compromising the performance of the EMI filter. This situation was solved by the inclusion of a 'shielding' PCB between the other two boards. This third board is simply a layer of copper with no circuitry. It is electrically connected to the junction of the negative output of the EMI filter and the negative input to the converter board. The final assembly then consists of a stack of three circular boards. This simple and inexpensive addition solves the coupling problem and results in the EMI performance demanded.

Performance

The reference design meets all of the design objectives. When used with 120 Vac nominal input voltages, the circuit efficiency is over 62 percent. The efficiency is over 56 percent with 220/240 Vac input voltages. Conducted EMI characterization was performed at both 115 Vac and 230 Vac inputs using both quasi-peak and average readings based on the EN55022A limits. The worst case configuration was at 230 Vac input, where the circuit passed with a margin of 7 dB. Margins were higher at 115 Vac input. Additional EMI plots along with waveforms of operation during both normal operation

and start-up are included in the referenced test report.

Conclusion

In spite of the physical constraints, therefore, it is perfectly possible to integrate a high performance electronic ballast for a HB LED bulb into a standard lamp housing cost-effectively and still meet EMI and power quality standards. The design is extensively supported with application notes, design tools, and a new LED lighting microsite. The avail-

ability of the RDK-131 reference design will allow new HB LED lighting products to be introduced with a fast time-to-market and alleviate the current scarcity of offerings that address important EMI questions.

www.powerint.com



Coping with New Lighting Requirements in Portable System Designs

Every new development needs a design solution

Recent advances in power management help designers offload processing overheads, drive down system footprint, and costs.

By Adolfo Garcia, Product Line Director for Lighting Products, AnalogicTech

Lighting requirements in hand-sets and portable devices have undergone a dramatic evolution over the past few years. Not so very long ago a typical cellphone featured a simple passive LCD display with little or no backlighting. The greatest challenge designers faced was how to most efficiently drive a number of LEDs in parallel or in series without draining the system's battery.

As designers moved to higher performance colour displays and began to embed a wide variety of value-added features such as cameras into their portable systems, power requirements have dramatically escalated. Today the typical cellular handset or handheld device features a relatively high resolution main display which is backlit by four or more LEDs. Many now also add a second, smaller display, such as those used on the outside of a clamshell-style phone, to deliver additional information. Usually these sub panels require two additional LEDs for backlighting. Power circuits are also often needed to drive auxiliary RGB status lights and to backlight the keypad on the device.

At the same time, the integration of camera functionality has brought an entirely new set of power requirements to portable system design. Embedded cameras require a flash typically

implemented by driving one, or a small number of LEDs at high power for a very short duration. Early camera implementations, which used CCDs of less than 1 Mega-pixel, demanded flash drivers of little more than 100mA. But as portable system designers have moved to higher resolution CCDs, power requirements for flash functions have risen as well. Today many portable devices require as much as 600mA (or more for Xenon flash lamps) of power just to drive the camera flash function and achieve maximum photo resolution and red-eye correction. (see diagram: AAT3171 typical application). Furthermore, the addition of new flashlight or movie-mode functions promises to further complicate power management requirements and system design.

Discrete implementations

Traditionally, portable system designers have relied primarily on discrete implementations to manage power for lighting applications. For backlight applications, designers have typically used discrete charge pumps to drive a number of LEDs in parallel or boost converters to drive a number of LEDs in series to provide basic illumination. Colour displays increased power require-



ments, but few early implementations offered designers any flexibility in terms of setting light intensity. Gradually, issues such as white balancing to control light intensity and colour balancing to create different colours for status lighting became increasingly important and required more sophisticated control by the system controller or a housekeeping microcontroller. Early on, most designers relied on relatively noisy analogue PWM control signals to control LED brightness and backlight functions.

Flash LED functions were first implemented as single units with simple on/off control. Designers later added rudimentary algorithms residing in the system processor to control the flash subsystem. Since few systems offered any flash intensity control, designers

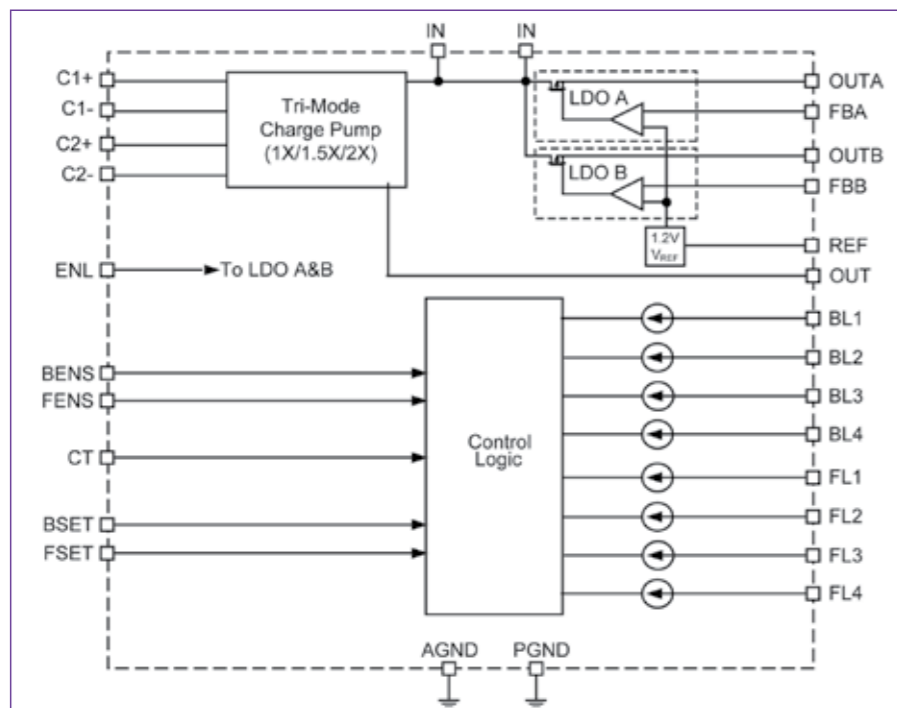

One of the risks associated with integrating multiple functions on a single IC is the limitation it potentially places on the designer's ability to configure the system. To maximize design flexibility, these devices add two separate serial interfaces that allow the designer to drive the LEDs for backlight or keypad functions and the LEDs for flash applications independently. With these independent interfaces designers can enable, disable or set current up to 16 different levels for backlight/keypad and flash functions. In addition, by allowing the designer to tune the output of the backlight or flash LEDs to their respective applications, this capability also helps save power. Alternately, the backlight/keypad and flash LEDs can be controlled via external resistors.

Other new highly integrated power management ICs help designers develop more efficient and cost effective solutions when they have to backlight multiple displays or add auxiliary lighting. These devices combine a high efficiency tri-mode charge pump with drivers for backlight LEDs, camera flash and auxiliary lighting. Instead of just driving four LEDs for backlight functions, however, these ICs drive up to six. By supplying individual control for each channel, these new devices allow designers to drive up to four LEDs to backlight a main display and two for a sub panel or use all six to backlight a single display.

Some of these new ICs, such as AnalogicTech's AAT2830, supply up to 600mA to drive up to four flash LEDs and support increasingly common requirements for flashlight and movie-mode applications. Moreover, they add

controlled the amount of light reaching the CCD by managing the camera shutter. As embedded camera performance improved, however, designers were forced to also upgrade the performance of their flash power management system. These advances demanded a fixed camera shutter and better control of the amount of light emitted by the flash. To reduce the overhead on the system controller, designers gradually migrated to more intelligent flash LED controllers. But as market pressure to reduce system size and cost has continued to mount, and the number, variety and complexity of lighting functions has continued to expand, portable system designers have begun to look for new ways to replace these discrete lighting subsystems.

Maximizing integration

Recently, power management semiconductor manufacturers have announced major advances in the vertical integration of these functions. By combining many of these circuits into a single IC, these new devices reduce component count, shrink PCB space requirements, minimize the overhead requirements of the system processor, and help portable system designers drive down cost.

As a result, instead of using a dedicated white LED driver for display backlight

applications, a dedicated camera flash driver IC and discrete general purpose LDOs or a dual LDO IC, designers can now use highly integrated ICs, such as AnalogicTech's AAT2842 Total Display Solution to combine all three functions in a single 4 x 4mm package (See diagram: AAT2842 block diagram). These complex circuits combine a high current tri-mode charge pump with four 30mA outputs for backlight white LED, four 150mA outputs for flash LEDs and two general purpose 200mA LDOs. The four flash LED outputs can be combined to drive a single camera flash LED at up to 600mA, sufficient power to support the light requirements of today's high resolution embedded cameras. The backlight outputs can also be used for lower current keypad applications. Each LDO is capable of supplying a continuous load current of 200mA at a 200mV drop-out voltage. In addition, the output voltage of each of the LDOs embedded in this display power management device is user programmable via a resistor divider from 1.2 to 5V allowing them to meet the power requirements of a broad range of functions. To help simplify design, a single control enables both LDO outputs.

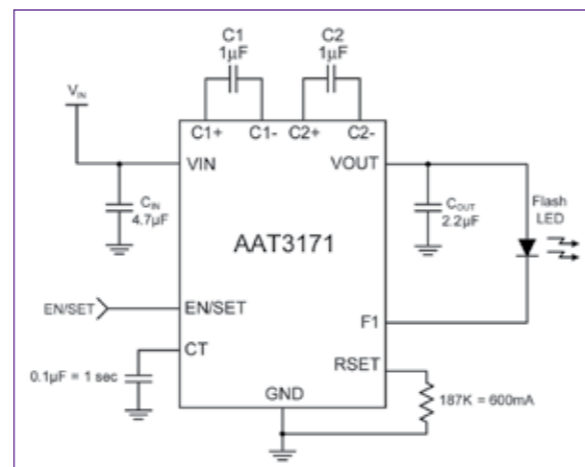

three additional drivers capable of handling up to 60mA each for RGB, keypad or other auxiliary lighting applications. The tri-mode charge pump sitting at the heart of these new devices is typically capable of supplying enough power to operate all three types of LED functions – backlight, flash and auxiliary – simultaneously.

To help reduce overhead on the system controller, many of these new display power management ICs also add an integrated flash timer. Traditionally, portable system designers have relied on a high-to-low transition on the flash enable pin to control the duration of a flash event. If the system controller software hangs up or the control line becomes disconnected, the designer using this architecture runs the risk of the flash LEDs staying on at full power. Since flash LEDs are only designed to work in very short bursts, a failure of this type could quickly damage the LEDs and rapidly deplete battery power.

The recent addition of integrated flash timers into this new generation of display power management ICs not only reduces overhead at the system controller, but also provides a unique safety feature to protect against these types of failures. This timer function enables the flash current sinks for a programmed amount of time. Length of on-time is set by loading the timing register in the device with a value and then selecting a value for an external timing capacitor. Once data is latched into the timing register, the flash current sinks are automatically enabled for the duration of the programmed time and then disabled. By letting the controller 'set and forget' the on-time duration, this integrated timer eliminates the need for the controller to track the duration of the flash event. It also ensures that the flash LEDs will only be illuminated for the prescribed amount of time limited by the value of the capacitor.

Conclusion

The continual evolution of lighting functions in portable system designs shows no signs of slowing. Next generation systems will likely add new lighting requirements as designers bring an ever-widening array of functionality to users. Inevitably, these innovations will pose new power management challenges for designers.

To address these power management issues, semiconductor manufacturers are already developing a wide

range of devices that bring together new combinations of charge pumps, boost converters and backlight, flash, RGB and LDO functional blocks. As these lighting features proliferate and the size of mobile communications and personal electronics products continue to shrink, this new generation of vertically-integrated, system-level devices will play a pivotal role in designers' quest for lower cost, higher performance systems.

www.analogictech.com

Dual High Efficiency White LED Drivers with Integrated Schottky Diodes can Drive 12 LEDs

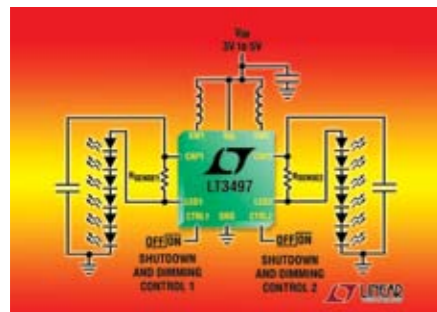

Dual Function White LED Driver with Integrated Schottky Diodes

Linear Technology has announced the LT3497, a dual, step-up DC/DC Converter designed to drive up to 12 white LEDs from a Li-Ion input. Its high efficiency, fixed frequency operation ensures uniform LED brightness, low noise and maximum battery life. The on-chip schottky diodes eliminate the added cost and space penalty of

external diodes. True Color PWM dimming enables dimming ranges of up to 250:1 without any colour shift of the LEDs. The LT3497's two independent converters are capable of driving asymmetric LED strings (up to 6 in series per converter) from an input voltage range of 2.5V to 10V. The 3mm x 2mm DFN package and tiny externals provide a very compact footprint for space-constrained handheld applications.

A 2.3MHz constant switching frequency enables the designer to minimize both solution footprint and switching noise and the wide input voltage range enables operation from single or dual cell Li-Ion powered handheld devices. High side current sense enables each string of LEDs to be driven by a single wire. As the same current is delivered to each LED-regardless of fluctuations in the LED's

forward voltage drop over temperature, manufacturing tolerances and age-brightness remains uniform.

Although on the same chip, the independent step-up converters are capable of driving asymmetric LED strings, with independent dimming and shutdown control of each string. Additional features include internal soft-start/inrush current limiting and open LED protection. This combination of attributes make the device ideal for backlighting applications that require many white LEDs in a tiny form factor.

The LT3497 is available in a 3mm x 2mm DFN-10 package.

www.linear.com

Cost-Effective LEDs Offer High Luminous Intensity and ESD Capability



Vishay Intertechnology has released a new series of sapphire-based, high-intensity white SMD LEDs that offer highly efficient InGaN technology at a very low price.

The new VLMW41XX series of SMD LEDs provides cost-effective illumination for applications including automotive dashboard backlighting and switches, indicators and backlighting in telecommunications systems, audio and video equipment, and office equipment;

and flat backlighting for LCDs, switches, and symbols in general use.

The devices offer a 60° angle of half-intensity, an extremely high luminous intensity ranging from 112 mcd to 355 mcd, and a typical colour temperature of 5500K. The LEDs feature an ESD-withstand voltage up to 2kV, in accordance with JESD22-A114-B.

The package for the new series is the EIA- and ICE-standard PLCC-2, which consists of a lead frame embedded in a white thermoplast. The reflector inside the package is filled with a mixture of epoxy and TAG phosphor. The TAG phosphor converts the blue emission partially to yellow, which mixes with the remaining blue to produce white.

Preconditioned according to JEDEC Level 2a standards, the PLCC-2 package is lead (Pb)-free and RoHS-compliant. CECC compatibility with

infrared, vapour phase, and wave solder processes, as well as automatic placement equipment and IR reflow soldering, simplifies handling and automatic assembly.

The VLMW41xx devices are qualified according to AEC Q101 and available in 8mm tape.

www.vishay.com

Protected High-Side Intelligent Power Switches for Automotive Improve Power Density and Response Time



International Rectifier has introduced a new generation of fully-protected, high-side intelligent power switches (IPS) with enhanced packaging delivering improved power density and response times. The new IPS60xx family is designed for tough automotive applications, including lighting control, transmission and gearbox, solenoid drivers and brushed DC motor control in seats, window lifts, and wipers.

These new devices offer impressive $R_{DS(on)}$ specification and a smaller footprint for the overall solution with the full-featured IPS6011 delivering a maximum on-state resistance of 14mOhms in a DPak.

The IPS60xxPBF family integrates

power MOSFETs with a host of standard protection features for over-current, over-temperature, ESD, and active clamp. An integrated charge pump allows the device to be driven in high-side topologies without additional components. The reverse battery protection which actively turns on the output MOSFET during a reverse battery event, almost eliminates current flow through the body diode and significantly reduces power dissipation. These devices provide diagnostic feedback to the microcontroller, allowing detection of basic faults.

All devices are RoHS compliant, Q100-qualified for automotive applications and available in a variety of packages.

Data sheets and an application note (AN-1117) are available on the Web at www.irf.com.

www.irf.com

Six-Channel Power Management ICs for Portable Electronic Designs

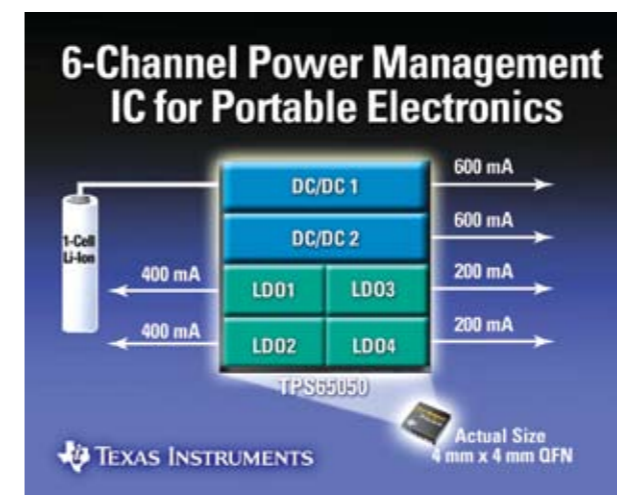

Texas Instruments has introduced a family of six-channel power management integrated circuits (PMICs) for single-cell, lithium-powered portable electronics. Combining high-performance power building blocks in a single 4mm x 4mm package, the easy-to-design devices support power system requirements of advanced

wide range of point-of-load currents up to 1A.

The TPS65050 integrates two 2.25MHz step-down converters to support the system's core, peripheral, I/O or memory voltages. The high frequency allows a designer to implement a tiny 2.2µH inductor and ultra-small capacitors to achieve a small

application processors used in smart phones, portable media players, navigation systems and other electronics.

These converters efficiently manage power in today's leading application processors, such as TI's OMAP™ processors, TMS320C55x™ generation of digital signal processors (DSPs) and others. The devices can achieve 95% efficiency across a

footprint. Both converters operate with an input range of 2.5V to 6V and enter power-save mode at light load currents. When power consumption is reduced to less than 1µA the device can be placed in shutdown mode.

The TPS65050 also integrates two general-purpose, 400mA linear dropout (LDO) voltage regulators and two 200mA LDOs that can be enabled with an external input pin for each. In addition, the LDOs support an input voltage between 1.5V and 6.5V, allowing each to be powered from one of the integrated step-down converters or directly from the battery.

The devices are available in a 32-pin, 4mm x 4mm leadless QFN package.

www.ti.com

MOSFETs Suit Ultra Low Gate Drive Operation

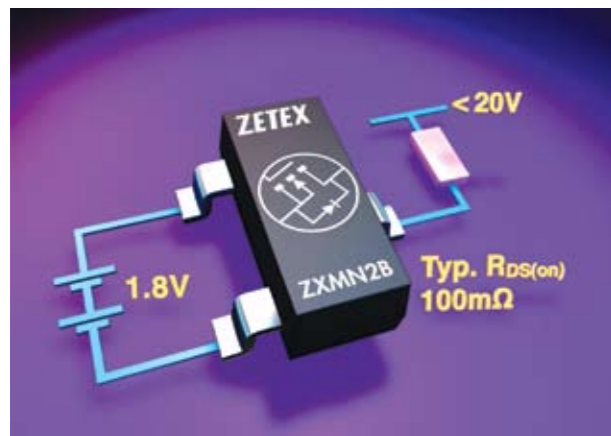

The 20V ZXMN2B03E6 (SOT236), ZXMN2B14FH and ZXMN2B01F (both SOT23) are capable of low loss switching at a V_{GS} of 1.8V, enabling them to be operated from two 1.2V cells or a single Li-Ion cell. Their ultra low gate drive also means they can be driven directly by logic gates.

level shifting for high side disconnect switches, external switching for boost converter circuits and buffering low voltage microcontrollers and loads such as motors and solenoids.

Fast switching performance is another key feature of the company's proprietary UMOS technology. For example, the ZXMN2B01F rise and fall times are just 3.6ns and 10.5ns, for $V_{GS}=4.5V$ and $I_D=1A$.

www.zetex.com

Zetex Semiconductors has introduced three new N-Channel enhancement mode MOSFETs, developed specifically for applications with limited drive voltage availability.

$R_{DS(ON)}$ for the three MOSFETs is respectively guaranteed to be less than 75m Ω , 100m Ω and 200m Ω at 1.8V $_{GS}$ and 40m Ω , 55m Ω and 100m Ω at 4.5V $_{GS}$. This makes them ideal for low voltage roles including

Cost-Effective LEDs Offer High Luminous Intensity and ESD Capability



Micrel has launched the MIC2810, a highly efficient, flexible power management IC that provides three output voltages and a power on reset in a tiny 3mm x 3mm MLF $\text{\textcircled{R}}$ -16 package. The solution is ideal for use in cell phones, smart phones, PDAs, cameras, portable media players, wireless LAN cards and Bluetooth applications. The device is also suited to powering Complex Programmable Logic Devices (CPLDs) from a 3.3V or 5V rail in general purpose applications.

"The MIC2810 offers the maximum flexibility to power DSPs, CPLDs and graphics chipsets which often require up

to three voltages," noted Ralf Muenster, Micrel's director of marketing for power products. "Usually, the lower core voltage has the higher current requirement and an efficient buck regulator is the ideal power solution, while the I/O and memory rails can be powered using LDOs. The MIC2810 provides these three

voltages in a highly flexible, space and energy efficient solution, 25% smaller than current solutions on the market."

The MIC2810 features a wide input range of 2.7V to 5.5V, three voltage outputs and a power-on reset. Output 1 is a high frequency, high efficiency DC-to-DC switching regulator for up to 600mA while outputs 2 and 3 are low dropout linear regulators. One of the linear regulators can be directly connected to the output of a DC-to-DC converter or to directly to the main power rail.

The MIC2810 is a μ Cap design, operating with very small ceramic output

capacitors for stability and reducing solution footprint and cost. The DC-to-DC converter provides virtually no noise in light load mode and just 75 μ V $_{RMS}$ output noise in LOWQTM mode. This allows designers to avoid higher noisy light-load modes that have traditionally interfered with sensitive RF circuitry. The solution operates at 2MHz PWM in normal mode, more than 93% efficiency, and only requires a tiny 2.2 μ F output capacitor and a 2.2 μ H inductor for stability. The part also integrates a power-on reset (POR) circuit that monitors all three output voltages. Independent enables for the switching and two linear regulators allow for design flexibility. Consisting of one switching DC-to-DC and two LDOs, Micrel's MIC2810 solution footprint is 25% smaller than the smallest discrete solution currently on the market.

www.micrel.com

International Exhibition & Conference for
POWER ELECTRONICS
INTELLIGENT MOTION
POWER QUALITY
22 - 24 May 2007
 Exhibition Centre Nuremberg

Power On!

Mesago
PCIM
 Organizer:
 Mesago PCIM GmbH
 Rotebühlstraße 83-85
 D-70178 Stuttgart

Exhibition:
 Linda Raidt
 Tel. +49 711 61946-56
 E-Mail: raidt@mesago.de

Conference:
 Lisette Hausser
 Tel. +49 711 61946-85
 E-Mail: hausser@mesago.de

Tiny 3 MHz Synchronous Step-Down DC-DC Converter for Portable and Consumer Applications

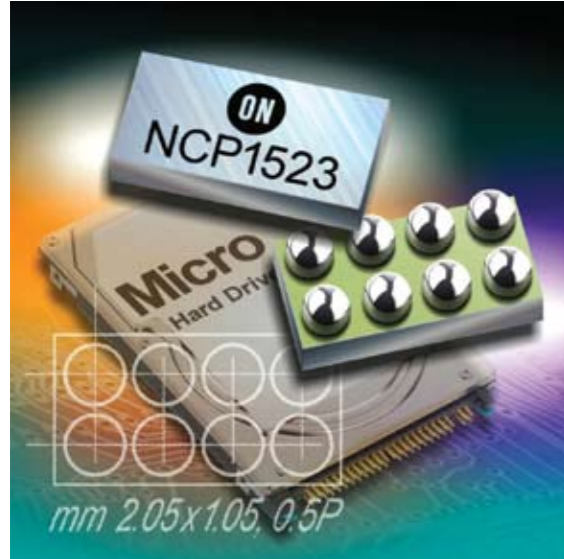

voltage with very low ripple voltage and fast transient response, the new devices are ideal for use in power sensitive applications such as micro hard disk drives found in multimedia portable devices.

The NCP1523 and NCP1523B feature a high switching frequency of 3 megahertz (MHz), which enables the use of a smaller inductor down to 1 micro Henry (μ H). The devices deliver high power efficiency - up to 93% due to synchronous rectification to extend battery life and

switching PWM/PFM modes, which improve system efficiency at a light load. The PWM-only mode, featured in the NCP1523B, offers an efficient load transient solution and low output voltage ripple. Additionally, these new devices offer integrated soft-start, cycle-by-cycle current limiting and thermal shutdown protection.

Available in an adjustable output voltage from 0.9 V to 3.3 V, the NCP1523 and NCP1523B are packaged in the tiny 2.1 mm x 1.1 mm 8-pin Flip-Chip.

www.onsemi.com

ON Semiconductor has introduced two new high-performing pulse width modulation (PWM), pulse frequency modulation (PFM) and PWM-only dc-dc converters optimized for portable applications. Supplying clean output

reduce external part count. To supply power to even the most demanding microprocessor in portable electronics, these new dc-dc converters provide very fast response times. The NCP1523 features automatic

Companies in this Issue

Company	Page	Company	Page
Ansoft	9	Linear Technology	56
APEX Microtechnology	15	Maxwell	4, 24
AnalogicTech	53	Method Electronics	C3
Actel Corporation	31	Micrel	34, 58
Bergquist	11	Microchip Technology	38
Cree	4	National Semiconductor	17
CT-Concept Technology	21	Nextreme Thermal Solutions	4
Dynex Semiconductor	22	ON Semiconductor	60
electronica China	25	OSRAM	4, 8
Fairchild Semiconductor	C2	P21	24
Fairchild Semiconductor	28	PCIM Europe	59
Giampaolo Pantaleoni	42	Power Integrations	6, 50
Infineon	19	Power Systems Design Europe	13, 40, 52, 55
Infineon	10, 45	Ridley Engineering	23
International Rectifier	C4	Ridley Engineering	14
International Rectifier	56	Summit Microelectronics	6
Intersil	47	Texas Instruments	5
iSuppli	12	Texas Instruments	6, 57
LEM	3	Vishay Semiconductors	57
LEM	20	Zetex Semiconductors	58
Linear Technology	7		

Please note: **Bold**—companies advertising in this issue

Complete Power Distribution Solutions

POWER RAIL™

The Innovative, Pluggable Rail Power Distribution System

- Power Ranges from 200 to 2000 Amps
- Single, Double, or Multi-Rail Options
- High Power Density
- Rapid Connect/Disconnect
- Interconnect Options Include Bus Bar or Cable and Connector
- Continuous Power Over Full Rail
- Ease of Installation
- Efficient Cost Per Amp
- Eliminates Discrete Connectors

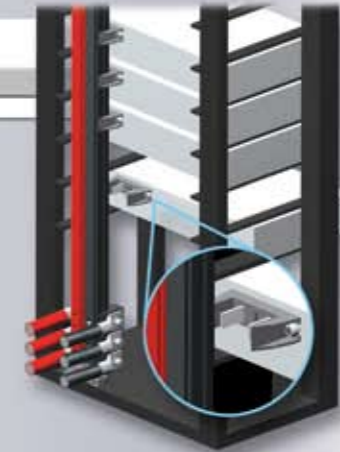

www.thepowerrail.com

METHODE ELECTRONICS, INC.

Europe - Ireland
Phone: +353 (0) 61 401222
Email: info@methode.com

Europe - UK
Phone: +44 (0)7736 341486
Email: m.cripwell@btopenworld.com

Europe - Germany
Phone: +49 175 5694642
Email: marcuskoerner@t-online.de

The Americas
Phone: 1-847-577-9545
Email: info@methode.com

www.methode.com



High Density Connectivity with Power SwivelNut



High Current Carrying PowerFlex & PowerFlex 1000



Low-Voltage Drop FusionLug



Low Inductance Parallel PowerCable



Bus Bar with Blind Mate Interconnects



Bus Bar with Discrete Circuits for a Military Application



Bus Bar for Pluggable Circuit Breakers



Multiple Connections with Minimal Voltage Drop

✓ RoHS Compliant

IR SETS THE STANDARD FOR 600V ICs

Rugged, Reliable, Highly Integrated

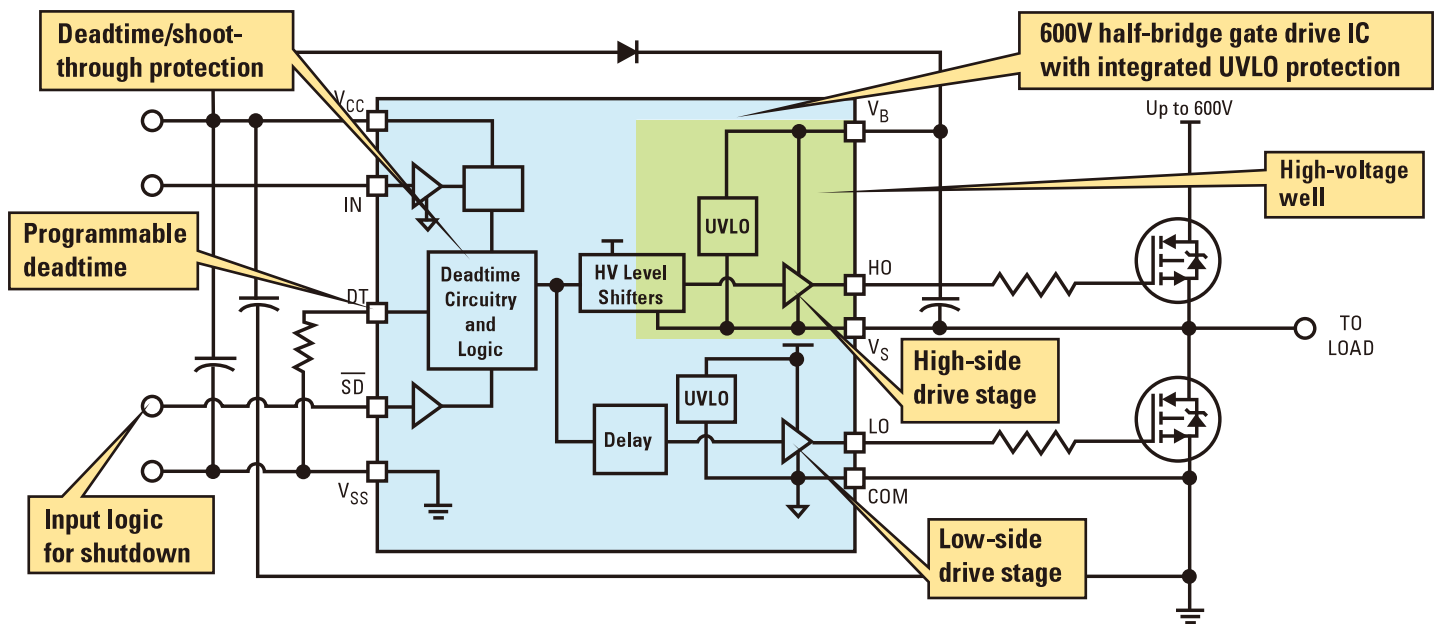

HALF-BRIDGE DRIVER ICs

Part Number	Pin Count	Sink/Source Current (mA)	Comments
IRS2103(S)PBF	8	290/600	UVLO V_{CC}
IRS2104(S)PBF	8	290/600	Input logic for shutdown; UVLO V_{CC}
IRS2108(S)PBF	8	290/600	UVLO V_{CC} & V_{BS}
IRS21084(S)PBF	14	290/600	Programmable deadtime; UVLO V_{CC} & V_{BS}
IRS2109(S)PBF	8	290/600	Input logic for shutdown; UVLO V_{CC} & V_{BS}
IRS21094(S)PBF	14	290/600	Input logic for shutdown; programmable deadtime; UVLO V_{CC} & V_{BS}
IRS2183(S)PBF	8	1900/2300	UVLO V_{CC} & V_{BS}
IRS21834(S)PBF	14	1900/2300	Programmable deadtime; UVLO V_{CC} & V_{BS}
IRS2184(S)PBF	8	1900/2300	Programmable deadtime; UVLO V_{CC} & V_{BS}
IRS21844(S)PBF	14	1900/2300	Input logic for shutdown; programmable deadtime; UVLO V_{CC} & V_{BS}

INDEPENDENT HIGH- AND LOW-SIDE DRIVER ICs

Part Number	Pin Count	Sink/Source Current (mA)	Comments
IRS2101(S)PBF	8	290/600	UVLO V_{CC}
IRS2106/IRS21064(S)PBF	8 / 14	290/600	UVLO V_{CC} & V_{BS}
IRS2181/IRS21814(S)PBF	8 / 14	1900/2300	UVLO V_{CC} & V_{BS}

IR's 600V ICs for motor control, lighting, switch-mode power supplies, audio, and flat-panel display applications deliver more features and greater functionality to simplify your circuit design and reduce risk.

IR's latest-generation high-voltage IC technology delivers superior protection and higher field reliability in an intelligent, monolithic driver IC.

Our new ICs are offered with single or dual inputs, under-voltage lockout protection, and fixed or programmable deadtime for half-bridge drivers.

Features:

- 3.3V logic compatible input
- Drive current up to 2.5A
- SO-8 package available*
- Separate COM and logic ground*
- UVLO protects V_{BS} *

**select models*

International
IR Rectifier

THE POWER MANAGEMENT LEADER

For more information call +44 (0)1737 227215
or +49 (0) 6102 884 311 or visit us at
www.irf.com/product-info/hvic